

Engineered Chain | Polymeric Chain & Accessories
(English-Inch)

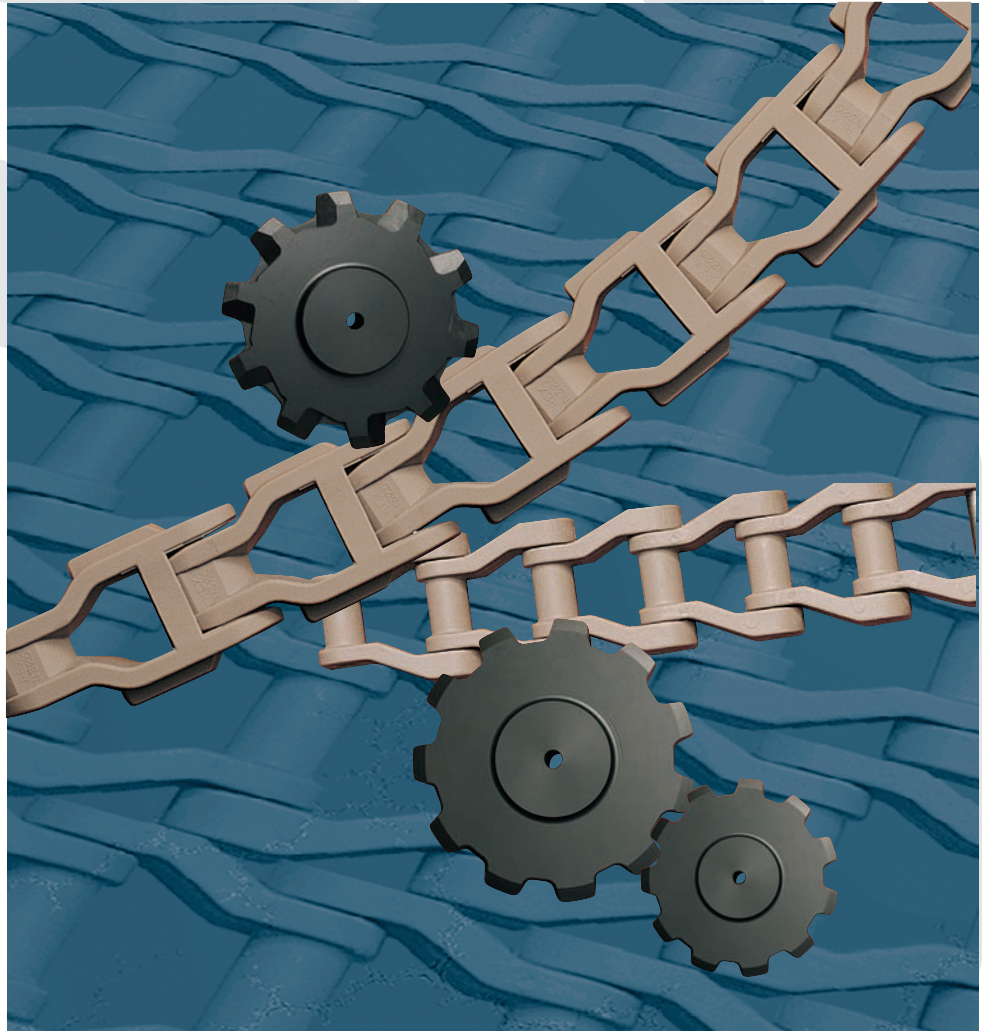

POLYMERIC CHAINS AND ACCESSORIES

STRAIGHT RUNNING CHAINS

Design Features

Rex straight running polymeric chains are designed specifically for those applications requiring corrosion resistant chains that operate over standard metal or polymeric sprockets.

The link material is a low friction thermoplastic that has proven itself as a chain material for over a decade. This material resists most chemicals, and because of its low friction characteristics, reduces energy consumption and noise while increasing chain, sprocket and conveyor wear strip life. Wide wearing surfaces on top and bottom of the link offer extended sliding wear life.

Chain pins are manufactured from stainless steel. The latest technology in chain design has been used to provide the greatest chain strength and wear life at a reasonable cost. The use of stainless steel pins with the corrosion resistant thermoplastic material offers a chain capable of withstanding most corrosive applications. Non-metallic pins are also available, contact Rexnord for details.

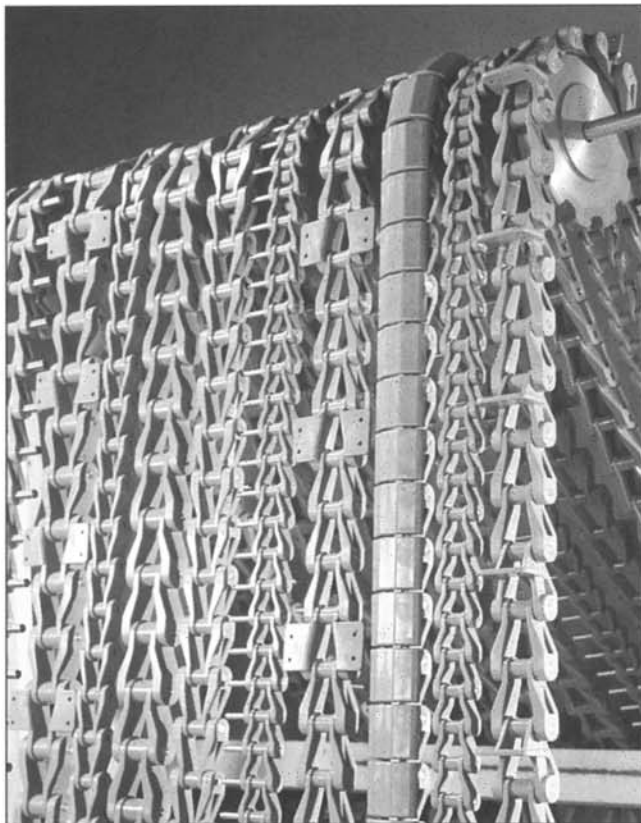

Design Benefits

- **Simple Two Piece Construction** – Pins are easily assembled into links – yet pins will not “work out” or rotate in service. No extra spring pins or cotters to fall out or snag conveyor apparatus. Every link is a “Master Link.”
- **Lightweight** – Less “dead weight” in your conveyor system will extend conveyor component life – longer chain life – longer conveyor “way” life – longer sprocket life – longer bearing life – longer reducer life – longer motor life!
- **Clean** – In normal service, Rex Polymeric Chain will not corrode and contaminate the product. It is easily washed with water during operation, saving both time and money.
- **Completely Interchangeable** – As a replacement for metal chains, Rex Polymeric Chain will run on existing carrying and return “ways.” The chains will not intercouple with metal chains.
- **Low Coefficient of Friction** – Rex chain materials have a very low coefficient of friction – this means less chain load and less energy consumption to convey the same tonnage.
- **Brute Strength** – Rex Polymeric Chain has the highest possible working load. This is accomplished through “Balanced Design” of the link and pin. For a comparison to your current chain or for chain recommendations consult Rexnord.
- **Operating Range** – Allowable temperature range of Rex Polymeric Chain is enough to handle most applications: -40°F to +180°F.
- **Quiet Running** – Because of its unique design, the Rex Polymeric Chain is an ideal chain for reducing noise in many applications. Make your own test to prove if the noise level is adequate for your needs.

Note: Dimensions are subject to change. Certified dimensions of ordered material are furnished upon request.

POLYMERIC CHAINS AND ACCESSORIES

STRAIGHT RUNNING CHAINS

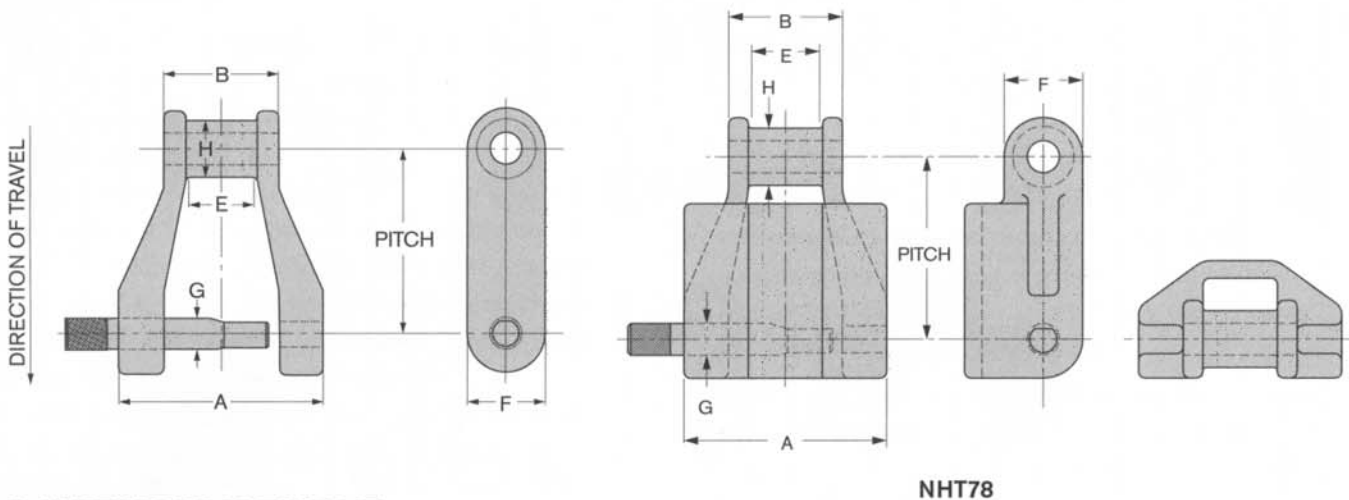

DIMENSION TABLE

Dimensions (Inches) and Weights (Pounds)										
Rex Chain No.	Average Pitch Inches	Overall Width	Length of Bearing	Max. Allowable Spkt. Face	Height of Side Bar	Diameter		Average Weight Per Foot	Spkt. Unit No.	Bottom Sliding Area Sq. Inches Per Foot
						Pin	Barrel			
		A	B	E	F	G	H			
NH45	1.630	2.19	1.31	.75	.88	.31	.63	0.9	N45	8.8
NH77	2.308	2.19	1.31	.75	1.10	.38	.81	1.1	N77	10.4
NH78	2.609	2.91	1.63	.94	1.13	.44	.88	1.4	N78	11.5
NHT78	2.609	2.91	1.63	.94	1.69	.44	.88	2.0	N78	11.5
NH82	3.075	3.29	2.00	1.13	1.50	.50	1.25	2.2	N82	13.7

Chains are normally stocked. Chains are patented: #4682687

CAUTION: ANY UNUSUAL burrs, ridges or protrusions on sprocket teeth or in conveyor system which would cut into polymeric chains must be removed.

Specifications

FDA and USDA – Chain materials used are in compliance with FDA regulations and guidelines for use in direct food contact. Also, the chain materials have been found chemically acceptable for direct food contact with meat or poultry products by the Product Safety Branch of USDA. Also, the chain designs have been found acceptable for direct contact with meat or poultry products by the Equipment Branch of the Facilities, Equipment and Sanitation Division of USDA.

See pages 161-163 for important application information.

NOTE: The purpose of the table below is to account for cycles of load. This is an important consideration relating to fatigue and is critical to the successful application of chains made from any nonmetallic material.

DIMENSION TABLE

Rated Working Load*				
Ratio of Chain Speed (FPM) To Sprocket Centers (FT)	Rated Working Load – Pounds			
	NH45	NH77	NH & NHT78	NH82
0.1	800	1100	1750	2400
0.2	750	1050	1650	2250
0.5	700	950	1350	2100
1.0	600	800	1100	1700
2.0	500	680	925	1400
5.0	400	540	750	1200
10.0	330	450	650	950

*Working load ratings for Polymeric Chains are established according to chain speed (FPM) and sprocket centers (FT).

Note: Dimensions are subject to change. Certified dimensions of ordered material are furnished upon request.

POLYMERIC CHAINS AND ACCESSORIES

STRAIGHT RUNNING CHAINS – Attachments

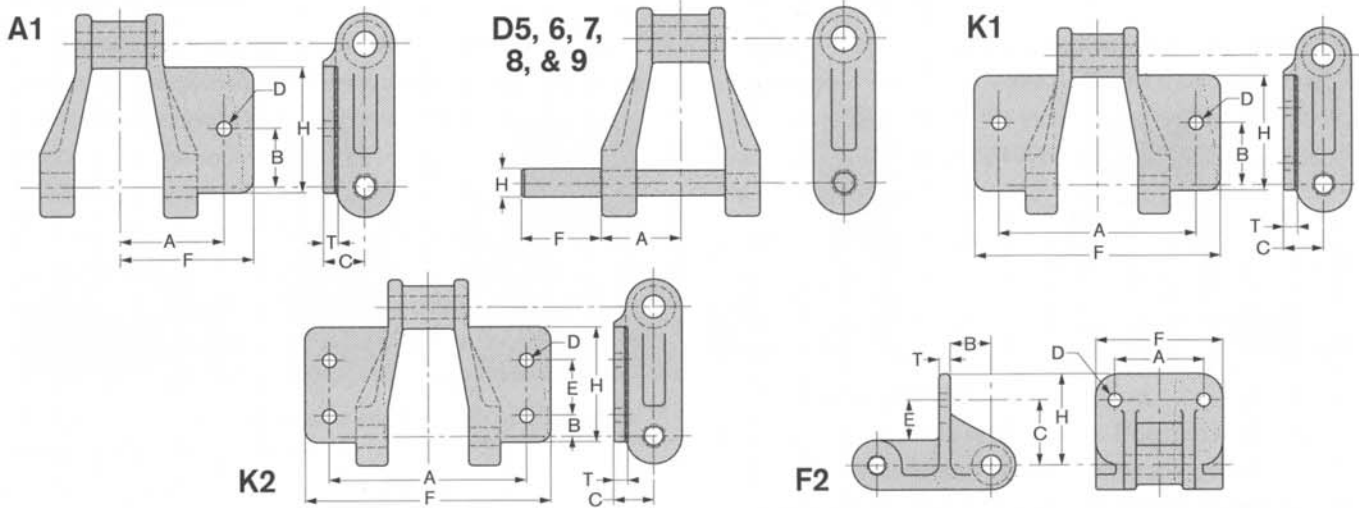

DIMENSION TABLE

Rex Chain No.	Attachments Dimensions (Inches) and Weights (Pounds)											
	A	B	C	D ^①		E	F	H	T	Weight Per Foot Lbs.	Link Weight W/O Pins Per 100 Pieces	Pin Weight Per 100 Pieces
				Bolt Dia.	Bolt Hole							
A1												
NH45	1.63	.38	.69	1/4	.28	–	2.00	1.47	.19	1.4	9	4.5
NH78	1.94	1.06	.81	1/4	.28	–	2.50	2.31	.25	1.7	25	11.8
NH82	2.13	1.00	.88	1/4	.28	–	2.69	2.25	.31	2.4	44	17.8
D5												
NH45	1.09	–	–	–	–	–	1.50	.31	–	1.1	7	7.7
D6												
NH45	1.09	–	–	–	–	–	1.50	.38	–	1.2	7	9.2
NH77	1.09	–	–	–	–	–	1.50	.38	–	1.3	13	11.2
D7												
NH45	1.09	–	–	–	–	–	1.50	.44	–	1.3	7	10.8
NH78	1.44	–	–	–	–	–	1.50	.44	–	1.7	20	18.2
NH82	1.66	–	–	–	–	–	1.50	.44	–	2.6	43	24.2
D8												
NH45	1.09	–	–	–	–	–	1.50	.50	–	1.5	7	12.8
NH78	1.44	–	–	–	–	–	1.50	.50	–	1.8	20	20.1
NH82	1.66	–	–	–	–	–	1.50	.50	–	2.7	43	26.1
D9												
NH45	1.09	–	–	–	–	–	1.50	.56	–	1.6	7	15.0
NH78	1.44	–	–	–	–	–	1.50	.56	–	1.9	20	22.4
NH82	1.66	–	–	–	–	–	1.50	.56	–	2.8	43	28.3
F2												
NH78	2.03	.94	1.47	1/4	.28	.90	2.90	2.06	.25	1.7	25	11.8
NH82 ^②	2.22	1.25	1.91	1/4	.28	1.25	3.28	2.50	.38	2.5	46	17.8
K1												
NH45	3.25	.38	.69	1/4	.28	–	4.00	1.47	.19	1.2	12	4.5
NH78	4.00	1.25	.81	1/4	.28	–	5.00	2.31	.25	1.9	30	11.8
NH82	4.25	1.00	.88	1/4	.28	–	5.38	2.25	.31	2.6	49	17.8
K2												
NH45	3.25	–	.69	1/4	.28	.81	4.00	1.47	.19	1.2	12	4.5
NH78	4.00	.41	.81	1/4	.28	1.13	5.00	2.31	.25	1.9	30	11.8
NH82	4.25	.34	.88	1/4	.28	1.31	5.38	2.25	.31	2.6	49	17.8

☐ Shaded attachments are most commonly used and are more readily available.

① Style of hole: round.

② Custom bolt-on attachment available – contact Rexnord.

A attachments are available right hand and left hand.

A, F, and K attachments are available blank (no holes), with holes as shown, or as required.

Note: Dimensions are subject to change. Certified dimensions of ordered material are furnished upon request.

POLYMERIC CHAINS AND ACCESSORIES

DOUBLE FLEX CHAINS

Design Features

The Rex Polymeric Double Flex Chains are designed for curved or straight unit handling conveyors. The chain will flex in the vertical and horizontal planes.

The chains are made from an exclusive low friction material that has proven itself as long wearing and shock resistant. With a stainless steel pin, the chains will not rust and will resist the same chemicals as acetal thermoplastic. Non-metallic pins are also available, contact Rexnord for details.

The latest technology in chain design has been used to provide the greatest chain strength and wear life at a reasonable cost.

Conveyor operators will appreciate the quiet running chains that reduce daily work area stress. Maintenance people laud the chain's light weight and ease of installation.

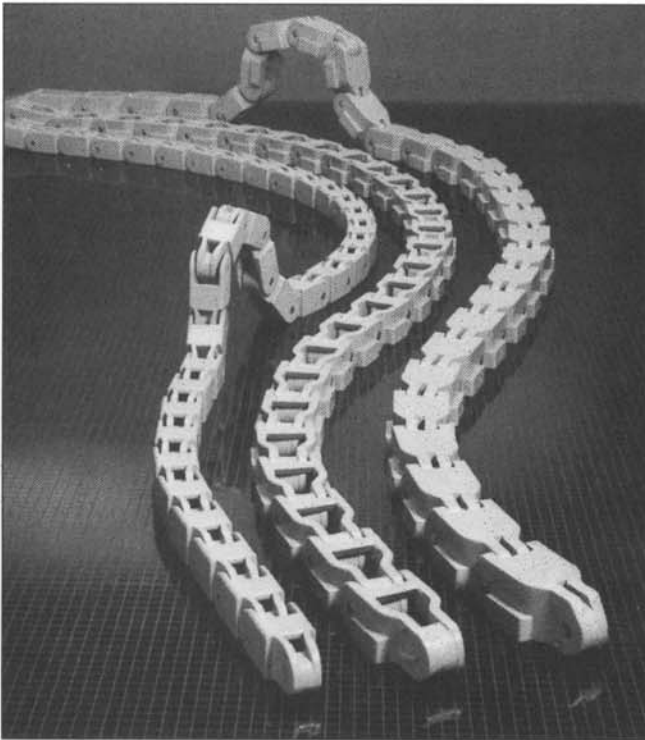

FDA and USDA – Chains materials used are in compliance with FDA regulations and guidelines for use in direct food contact. Also, the chain materials have been found chemically acceptable for direct food contact with meat or poultry products by the Product Safety Branch of USDA. Also, the chain designs have been found acceptable for direct contact with meat or poultry products by the Equipment Branch of the Facilities, Equipment, and Sanitation Division of USDA.

Design Benefits

- **Simple Two Piece Construction** – Pins are easily assembled into links – yet pins will not “work out” or rotate in service. No extra spring pins or cotters to fall out or snag conveyor apparatus.
- **Lightweight** – Less “dead weight” in your conveyor system will extend conveyor component life – longer chain life – longer conveyor “way” life – longer sprocket life – longer bearing life – longer reducer life – longer motor life!
- **Clean** – In normal service, chains will not corrode and contaminate the product. They are easily washed with water during operation, saving both time and money.
- **Easy Maintenance** – Chains are engineered for ease of assembly or disassembly. Since it is lightweight, a 10 foot strand of N325WS weighs 12 pounds, so one person can handle routine maintenance.
- **Operating Range** – Allowable temperature range of Rex polymeric chains is enough to handle most applications, -40°F to +180°F.
- **Completely Interchangeable** – A replacement for metal chains. These chains will run on existing carrying and return “ways.” Chains will not inter-couple with metal chains and require proper care with catenary design – consult Rexnord.
- **Low Coefficient of Friction** – Rex chain materials have a very low coefficient of friction. This means less chain load and less energy consumption to convey the same tonnage.
- **Brute Strength** – These chains have the highest possible rated Working Load. This is accomplished through “Balanced Design” of the link and pin. For a comparison to your current chain or for chain recommendations consult Rexnord.
- **Protects Conveyed Material** – The polymeric chains will not damage most products.
- **Quiet Running** – Because of its unique design, these chains are ideal for reducing noise in many applications... make your own test to prove if the noise level is adequate for your needs.

POLYMERIC CHAINS AND ACCESSORIES

DOUBLE FLEX CHAINS

See pages 161-163 for important application information.

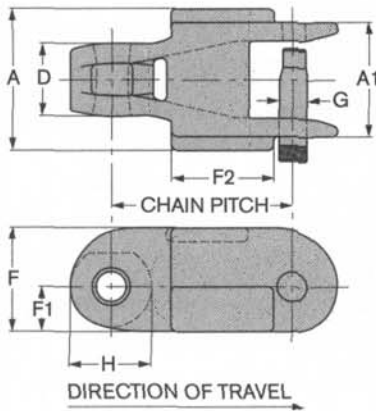

N250 (WS)*

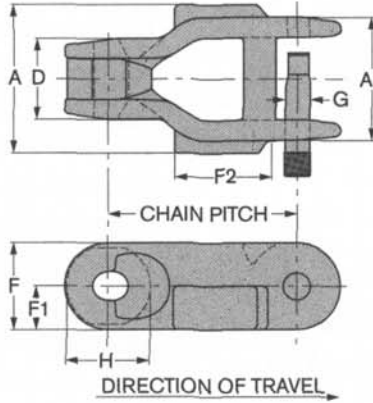

N325 (WS)*

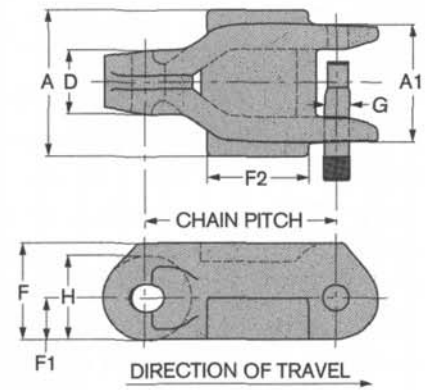

N9350 (WS)*

DIMENSION TABLE

Dimensions (Inches) and Weights (Pounds)													
Rex Chain No.	Average Pitch Inches	Overall Width		Length of Barrel	Maximum Allow. Spkt. Face	Height of Side Bar	Wear Shoe		Diameter of Pin or Rivet	Diameter of Barrel	Minimum Flex Radius	Average Weight Per Foot Lbs.	Bottom Sliding Area Incl. Wear Shoes Sq. In.
		With Wear Shoes	Without Wear Shoes				Height	Length					
		A	A1				F1	F2					
N250 (WS)	2.500	1.94	1.56	1.00	.75	1.44	.63	1.41	.38	1.13	20	0.9	2.1
N325(WS)	3.268	2.56	2.13	1.38	.63	1.50	.75	1.63	.44	1.44	24	1.2	3.2
N9350(WS)	3.500	2.66	2.13	1.16	.81	1.75	.75	1.84	.44	1.50	24	1.8	4.2

* Note: WS version has wear shoes. Chains are normally stocked. Chains travel open end forward. Chains are patented: #4682687

CAUTION: ANY UNUSUAL burrs, ridges or protrusions on sprocket teeth or in conveyor system which would cut into polymeric chains must be removed.

DIMENSION TABLE

Dimensions (Inches) and Weights (Pounds)			
Ratio Of Chain Speed (FPM) To Sprocket Centers (FT)	Rated Working Load - Pounds*		
	N250(WS)	N325(WS)	N9350(WS)
0.1	800	1500	1875
0.2	750	1500	1875
0.5	700	1250	1565
1.0	600	1030	1290
2.0	500	850	1065
5.0	400	650	815
10.0	330	540	675

*Working load ratings for Polymeric Chains are established according to chain speed (FPM) and sprocket centers (FT).

NOTE: The purpose of the table to the left is to account for cycles of load. This is an important consideration relating to fatigue and is critical to the successful application of chains made from any nonmetallic material.

Note: Dimensions are subject to change. Certified dimensions of ordered material are furnished upon request.

POLYMERIC "DROP FORGED" CHAINS

TOUGH, LIGHT, EASY TO MAINTAIN

• **Moisture Resistant** – Unique, patented Rex N348 polymeric chain operates exceptionally well in a water environment that would corrode ordinary metal chain. Its ability to operate in a wet environment has been proven by extensive laboratory and field testing. In addition, water serves as a lubricant for N348's non-metallic links and knuckles – extending chain life.

The dry operating temperature of N348 ranges from 0°F to +180°F. For continuous operation in water over 150°F, please consult Rexnord Inc.

• **Reduces Excess Weight** – N348 reduces chain weight in the conveyor system by 70% over metal chain. This light weight extends conveyor component life and cuts energy consumption providing more cost-efficient operation.

• **Simplified Service and Replacement** – Rex N348 chain can be washed with hot water and detergent without damage, as long as chain temperature stays below 150°F. N348 is interchangeable with existing drop-forged X348 chain, although inter-coupling is not recommended – but additional "drives" may be required. However, N348 will accept the same sprockets, turning wheels and trolley attachments.

Rex Polymeric Chain has good resistance to hydrocarbons and most neutral organic and inorganic materials, and to weak acids and weak bases in a pH range from 4 to 10.

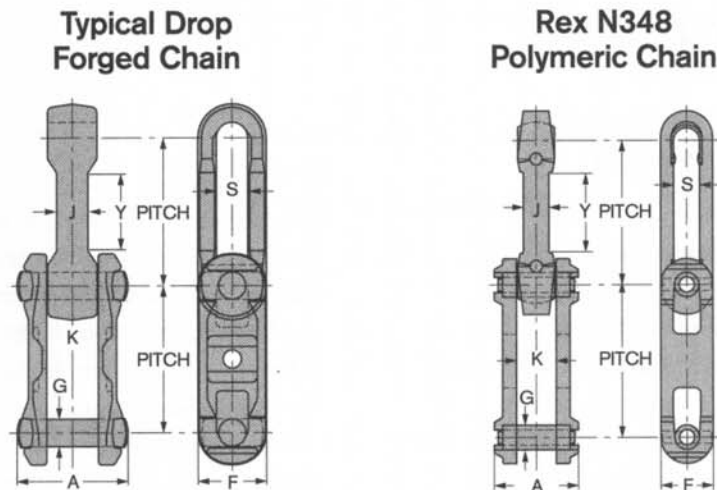

DIMENSION TABLE

Dimensions (Inches) and Weights (Pounds)										
Chain Number	Average Pitch	Pin Dia.	Overall Width	K	Chain Height	Link Thickness	S	Rated Working Load	Average Weight per Ft.	Sprocket Number ①
		G	A		F	J				
"X" Series Drop Forged Chain										
X348	3.015	0.50	1.75	0.81	1.09	0.50	0.56	2,000	2.2	348
"N" Series Polymeric Chain										
N348	3.015	0.50	1.75	0.81	1.09	0.50	0.50	700	0.6	348

① Cast or fabricated sprockets may be used.
Dimensions are in inches. Strengths, loads and weights are in pounds.

Note: Dimensions are subject to change. Certified dimensions of ordered material are furnished upon request.

■ SPROCKETS

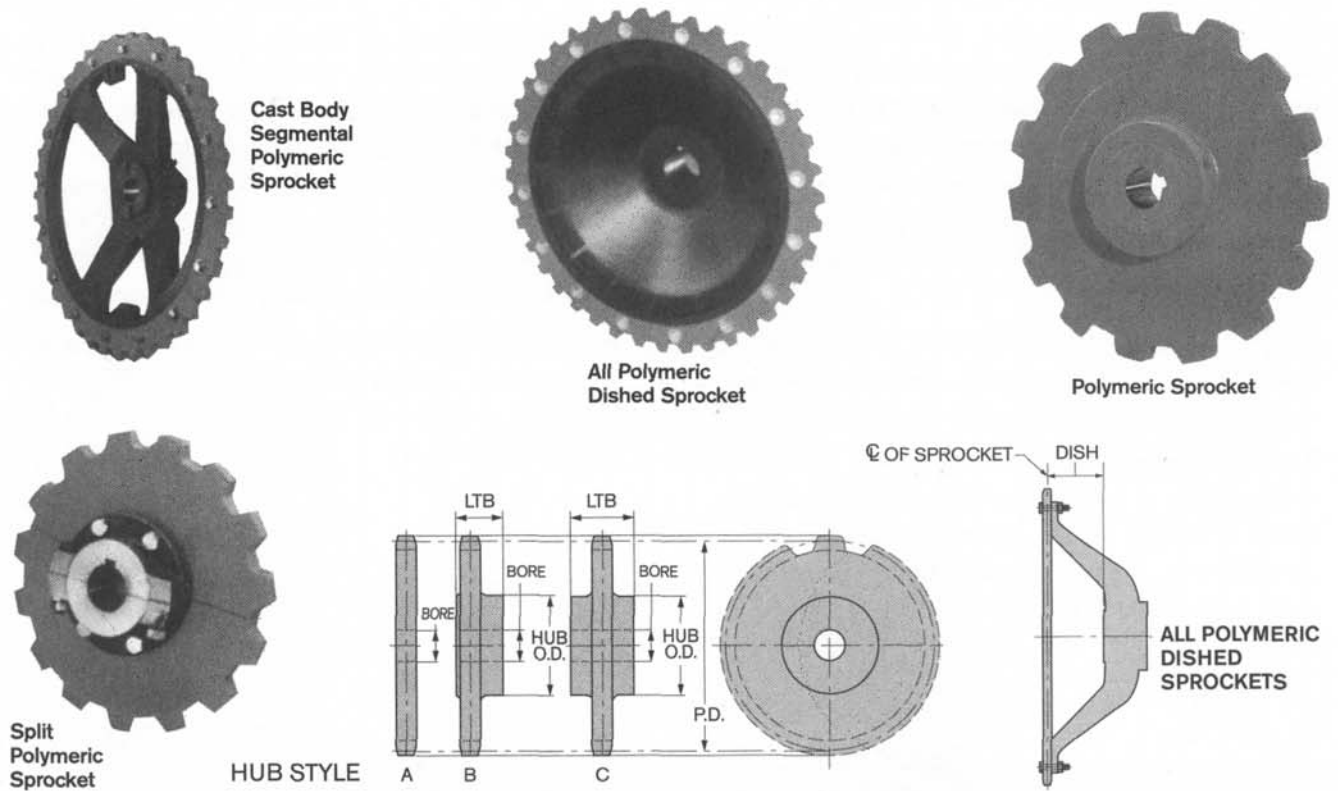

POLYMERIC SPROCKET AND IDLER WHEELS

Polymeric chains will provide the ultimate in service when operated with properly designed sprockets. Just like polymeric chains differ from metal chains, so do polymeric sprockets differ vastly from metal sprockets.

The polymeric sprocket must be designed for the particular chain, considering the chain's special capability and intended use. Many factors are taken into account when designing these sprockets: Tooth pressure angle, pitch line clearance, bottom diameter, pocket and topping radii and tooth working face, to name a few. A poor design in any of these areas may cause chain failure.

Rex® Polymeric sprockets increase chain and sprocket life by reducing corrosion and friction. Quiet running, shock absorbing sprockets also improve system reliability.

The American Chain Association recommends that "Sprockets normally be obtained from the manufacturer of the chain involved." The Association further cautions that "**worn sprockets should always be replaced when new chain is installed...**"

Features

- **Designed specifically for use with polymeric chains** for greatest chain and sprocket life.
- **Made from super tough urethane.** Rex sprockets resist particle embedment, a common problem with sprockets made from UHMWP that can result in rapid chain wear.
- **One-piece design** – Rex polymeric sprockets are all polymeric, or available with a steel insert cast integral with the body.
- **Absorbs vibration and large shock loads,** thus protecting the chain and providing quieter operation.
- **Reduces friction,** which improves chain life.
- **Split sprockets** – most sprockets are available in split design for ease of installation.

■ SPROCKETS

POLYMERIC SPROCKET AND IDLER WHEELS – (Cont'd.)

DIMENSION TABLE

Dimensions (Inches) and Weights (Pounds)									
	Number of Teeth	P.D.	Hub ^③		Bore Capacities			Weight ^③	
					W/O Key	With Key ^①			
			O.D.	L.T.B.	Max.	Min.	Max.		
N45 Polymeric Sprocket Pitch 1.630 Tooth Face at Pitch Line .75 Hub Style B Mandrel Bore .44	7	3.76	2.50	1.75	1.50	.88	1.25	.6	
	8	4.26	3.00	1.75	2.00	.88	1.25	.9	
	9	4.77	3.00	1.75	2.00	1.00	1.25	1.0	
	10	5.27	3.75	1.75	2.75	1.13	2.63	2.0	
	11	5.79	3.75	1.75	2.75	1.13	2.63	2.1	
	12	6.30	3.75	1.75	2.75	1.25	2.63	2.3	
	13	6.81	4.75	1.75	3.75	1.25	2.88	2.9	
	14	7.33	4.75	1.75	3.75	1.25	2.88	3.1	
	15	7.84	4.75	1.75	3.75	1.25	2.88	3.3	
	16	8.36	4.75	1.75	3.75	1.38	2.88	3.5	
	17	8.87	4.75	1.75	3.75	1.50	2.88	3.7	
	18	9.39	4.75	1.75	3.75	1.50	2.88	4.0	
	N77 Polymeric Sprocket Pitch 2.308 Tooth Face at Pitch Line .75 Hub Style B Mandrel Bore .44	7	5.32	3.75	2.00	2.75	1.25	2.25	1.1
		8	6.03	3.75	2.00	2.75	1.25	2.25	1.3
		9	6.75	4.75	2.00	3.75	1.25	2.88	1.2
		10	7.47	4.75	2.00	3.75	1.50	2.88	1.5
		11	8.19	4.75	2.00	3.75	1.50	2.88	1.7
		12	8.92	4.75	2.00	3.75	1.50	2.88	2.0
13		9.64	4.75	2.00	3.75	1.50	2.88	2.3	
14		10.37	4.75	2.00	3.75	1.63	2.88	2.7	
15		11.10	4.75	2.00	3.75	1.75	2.88	3.0	
N77 Polymeric Sprocket Tooth sprocket with Cast Iron Body Pitch 2.308 Tooth Face at Pitch Line .75 Hub Style C Deep or Shallow Dished	Number of Teeth	P.D.	Hub Diameter	L.T.B.	Bolt Circle	Max. Bore	Weight		
	39	28.68	②	②	25	②	②		

① Based upon keyed driver sprocket used with polymeric chain at the maximum rated working load. Consult Rexnord for information on steel hub inserts.

② Contact factory for hub sizes and weights.

③ Data without steel hub inserts.

IMPORTANT: Polymeric sprockets with steel hub inserts are recommended for applications using metal chains.

Note: Dimensions are subject to change. Certified dimensions of ordered material are furnished upon request.

SPROCKETS

POLYMERIC SPROCKET AND IDLER WHEELS – (Cont'd.)

DIMENSION TABLE

N78 Polymeric Sprocket Pitch 2.609 Tooth Face at Pitch Line .94 Hub Style B 7-15 Teeth Hub Style C 16-31 Teeth Mandrel Bore .94	Number of Teeth	P.D.	Hub ^③		Bore Capacities			Weight ^③
			O.D.	L.T.B.	W/O Key	With Key ^①		
					Max.	Min.	Max.	
7	6.01	3.75	2.25	2.75	1.25	2.25	2.4	
8	6.82	3.75	2.25	2.75	1.50	2.25	3.1	
9	7.63	4.75	2.25	3.75	1.50	2.75	4.7	
10	8.44	4.75	2.25	3.75	1.50	2.75	5.0	
11	9.26	4.75	2.25	3.75	1.63	2.75	5.7	
12	10.08	4.75	2.25	3.75	1.75	2.75	6.2	
13	10.90	4.75	2.25	3.75	1.88	2.75	6.7	
14	11.73	4.75	2.25	3.75	1.88	2.75	7.3	
15	12.55	4.75	2.25	3.75	1.88	2.75	8.0	
16	13.37	7.00	4.00	6.00	1.50	4.00	15.8	
17	14.20	7.00	4.00	6.00	1.63	4.00	16.7	
18	15.03	7.00	4.00	6.00	1.63	4.00	17.4	
19	15.85	7.00	4.00	6.00	1.63	4.00	18.2	
20	16.68	7.00	4.00	6.00	1.75	4.00	19.3	
21	17.51	7.00	4.00	6.00	1.88	4.00	20.2	
22	18.33	7.00	4.00	6.00	1.88	4.00	21.4	
23	19.16	7.00	4.00	6.00	1.88	4.00	22.3	
24	19.99	7.00	4.00	6.00	1.88	4.00	22.5	
25	20.82	7.00	4.00	6.00	1.88	4.00	24.6	
26	21.64	7.00	4.00	6.00	1.88	4.00	26.1	
27	22.47	7.00	4.00	6.00	1.88	4.00	27.1	
28	23.30	7.00	4.00	6.00	1.88	4.00	28.6	
29	24.13	7.00	4.00	6.00	1.88	4.00	30.3	
30	24.96	7.00	4.00	6.00	1.88	4.00	31.4	
31	25.79	7.00	4.00	6.00	1.88	4.00	33.0	

N78 Polymeric Sprocket Segmental Tooth Sprocket with Cast Iron Body Pitch 2.609 Tooth Face at Pitch Line .94 Hub Style C Deep or Shallow Dished Contact Factory For Hub Sizes and Weights	Number of Teeth	P.D.	Hub Diameter	L.T.B.	Bolt Circle	Max. Bore	Weight
40	33.25	②	②	30	②	②	
43	35.65			30			
48	39.89			30			
54	44.87			30			

N78 All Polymeric Dished Sprocket with Segmental Tooth Pitch 2.609 Tooth Face at Pitch Line .94 Hub Style C Shallow or Deep Dished • Shallow Dished (SD) 1.5", 1.75", 2" • Deep Dished (DD) 6.25", 6.5"	Number of Teeth	P.D.	Max. Hub Diameter	L.T.B.	Bolt Circle	Max. Bore	Weight
40	33.25	8.0SD	7.31	30	5.44	81	
40	33.25	10.0SD	5.00	30	4.94	93	
43	35.65	8.0SD	7.31	30	5.44	92	
43	35.65	10.0SD	5.00	30	4.94	101	
48	39.89	8.0SD	7.31	30	5.44	112	
48	39.89	10.0SD	5.00	30	4.94	122	

① Based upon keyed driver sprocket used with polymeric chain at the maximum rated working load. Consult Rexnord for information on steel hub inserts.

② Contact factory for hub sizes and weights.

③ Data without steel hub inserts.

IMPORTANT: Polymeric sprockets with steel hub inserts are recommended for applications using metal chains.

Note: Dimensions are subject to change. Certified dimensions of ordered material are furnished upon request.

SPROCKETS

POLYMERIC SPROCKET AND IDLER WHEELS – (Cont'd.)

DIMENSION TABLE

Dimensions (Inches) and Weights (Pounds)								
N82 Polymeric Sprocket Pitch 3.075 Tooth Face at Pitch Line 1.13 Hub Style B 7-8 Teeth Hub Style C 9-18 Teeth Mandrel Bore .94	Number of Teeth	P.D.	Hub ^③		Bore Capacities			Weight ^③
			O.D.	L.T.B.	W/O Key	With Key ^①		
					Max.	Min.	Max.	
	7	7.09	4.75	2.75	3.75	1.25	2.50	4.6
	8	8.04	4.75	2.75	3.75	1.38	2.50	5.2
	9	8.99	6.00	4.00	5.00	1.50	4.25	6.0
	10	9.95	7.00	4.00	5.00	1.50	4.25	6.8
	11	10.91	7.00	4.00	5.00	1.63	4.25	7.6
	12	11.88	7.00	4.00	5.00	1.75	4.25	8.6
	13	12.85	7.00	4.00	6.00	1.88	5.00	9.7
	14	13.82	7.00	4.00	6.00	1.88	5.00	10.8
	15	14.79	7.00	4.00	6.00	1.88	5.00	11.9
	16	15.76	7.00	4.00	6.00	1.88	5.00	13.0
	17	16.73	7.00	4.00	6.00	1.88	5.00	14.1
	18	17.71	7.00	4.00	6.00	1.88	5.00	15.2

N82 Segmental Sprocket Tooth sprocket with Cast Iron Body Pitch 3.075 Tooth Face at Pitch Line 1.13 Hub Style C Deep or Shallow Dished	Number of Teeth	P.D.	Hub Diameter	L.T.B.	Bolt Circle	Max. Bore	Weight
	36	35.28	②	②	25	②	②

N82 Polymeric Dished Sprocket with Segmental Teeth Pitch 3.075 Tooth Face at Pitch Line 1.3 Hub Style C Shallow or Deep Dished Shallow Dished (SD) 1.5", 1.75", 2" Deep Dished (DD) 6.25", 6.5"	Number of Teeth	P.D.	Max. Hub Diameter	L.T.B.	Bolt Circle	Max. Bore	Weight
	36	35.28	8.0SD	7.31	30	5.44	88
	36	35.28	10.0DD	5.00	30	4.94	100

N250 All Polymeric Pitch 2.500 Tooth Face at Pitch Line .63 Hub Style B Mandrel Bore .94	Number of Teeth	P.D.	Hub ^③		Bore Capacities			Weight ^③
			O.D.	L.T.B.	W/O Key	With Key ^①		
					Max.	Min.	Max.	
	11	8.87	4.75	2.25	3.75	1.50	3.00	3.5
	12	9.66	4.75	2.25	3.75	1.50	3.00	4.1
	13	11.24	6.00	2.25	5.00	1.75	2.75	4.5

N325 Polymeric Sprocket Pitch 3.268 Tooth Face at Pitch Line .81 Hub Style C Mandrel Bore .94	Number of Teeth	P.D.	Hub ^③		Bore Capacities			Weight ^③
			O.D.	L.T.B.	W/O Key	With Key ^①		
					Max.	Min.	Max.	
	10	10.58	4.75	3.00	3.75	1.50	3.00	5.7

N9350 Polymeric Sprocket Pitch 3.50 Tooth Face at Pitch Line .81 Hub Style C Mandrel Bore .94	Number of Teeth	P.D.	Hub ^③		Bore Capacities			Weight ^③
			O.D.	L.T.B.	W/O Key	With Key ^①		
					Max.	Min.	Max.	
	10	11.33	4.75	3.00	3.75	1.88	2.75	6.2

① Based upon keyed driver sprocket used with polymeric chain at the maximum rated working load. Consult Rexnord for information on steel hub inserts.

② Contact factory for hub sizes and weights.

③ Data without steel hub inserts.

IMPORTANT: Polymeric sprockets with steel hub inserts are recommended for applications using metal chains.

Note: Dimensions are subject to change. Certified dimensions of ordered material are furnished upon request.

■ SPROCKETS

DOUBLE-FLANGED POLYMERIC IDLERS

Corrosion resistant Polymeric Double-Flanged Idlers are designed for use with polymeric chains to insure longer system life and quieter operation. The six inch (DF6) and eight inch (DF8) diameter double-flanged idler wheels are manufactured from high-strength, wear-resistant polymeric material with a bronze bushing assembled into each idler. Some of the chains used on these wheels: NH45, NH77, NH78*, NHT78*, N250, N250WS, N325, N348, N9350, N9350WS. DF8 – NH45, NH77, NH78, NHT78, WH78, NH82, WH82, WH260, WH784, WHT78, WHT130, WHT138.

Features

- Made from polymeric and bronze materials that will not rust.
- Bronze bushed so that it can be used on non-rotating shafts as tail wheels, return support rollers, or drive take-up idlers.
- Double tapered flanges to effectively guide the chain into the center of the idler without unnecessary noise and chain wear.
- Engineered polymer reduces noise.
- Simple design means the idler is shaft ready and no machining is required.
- Designed so that two set collars will easily hold the idler in place.

* Must machine "D" Dimension to 3 inches.

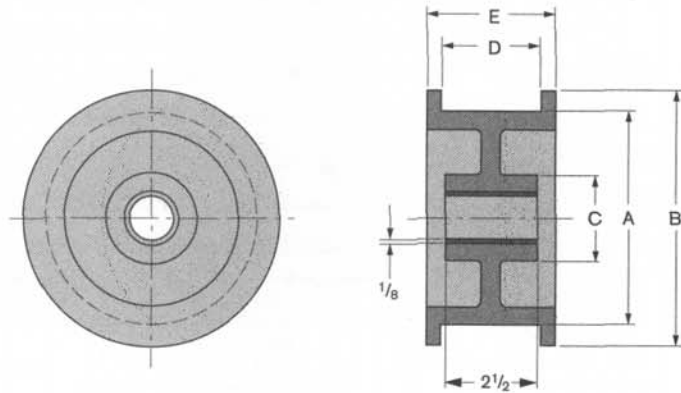

NOTE: For chains with extended rivets, single-flanged Polymeric idlers are available upon request.

DIMENSION TABLE

Dimensions (Inches) and Weights (Pounds)								
Double Flanged Idler Wheels	Diameter			Length Thru Bore (LTB)	Width		Max. Bore	Weight ^①
	Inside	Outside	Hub		Inside	Outside		
	A	B	C		D	E		
6 D.F. Wheel	6	7.25	3.25	2.50	2.69	3.50	1.44	2.8
8 D.F. Wheel	8	9.50	4.25	3.00	3.63	4.50	2.44	4.5

① Approx. – Not Bushed Wheels are normally stocked.

Note: Dimensions are subject to change. Certified dimensions of ordered material are furnished upon request.

■ DESIGN AND SELECTION

POLYMERIC CHAINS AND ACCESSORIES – APPLICATION INFORMATION

Materials

Standard Materials

The chain links are made from an acetal thermoplastic which distinguishes itself from both steel and stainless steel chains. The coefficient of friction for acetal is lower than either steel chains, reducing the horsepower requirement for the conveyor and preventing product damage when the chain slides under products backed up at various points in the conveyor. Acetal chains also reduce noise in a conveying system.

Combined with a stainless steel pin, the chain will not rust and has good resistance to many chemicals.

Special Materials

For applications requiring special chain capabilities, a wide range of materials and processing treatments have been developed. Consult Rexnord for details. (See the listing below for frequently encountered requirements).

FDA/USDA Compliance

Chain materials used are in compliance with FDA regulations and guidelines for use in direct food contact. Also, the chain materials have been found chemically acceptable for direct food contact with meat or poultry products by the Product Safety Branch of USDA. Also, the chain designs have been found acceptable for direct contact with meat or poultry products by the Equipment Branch of the Facilities, Equipment and Sanitation Division of USDA.

Environmental Factors

Chemical Resistance

polymeric chains, sprockets and idlers have good resistance to hydrocarbons, most neutral organic and inorganic materials, and to weak acids and bases in a pH range from 4 to 10.

To prolong chain life in the above situations, it is recommended to:

1. Avoid high temperatures of questionable liquids and/or solids. The closer to room temperature, the better.
2. Clean the chain! Thorough and frequent cleanings can limit prolonged exposure to questionable liquids and/or solids, decreasing the damaging effects of chemical attack.

Temperature Range

The allowable temperature range for Rex polymeric chains is -40°F to +180°F.

Consult Rexnord Corp. for operation beyond these temperatures.

Abrasion Resistance

Care should be taken when operating Rex polymeric chains in abrasive environments. Of particular concern is abrasive particles embedded in wearstrips and sprockets. These particles, once embedded, can work like a file to wear away the chain.

Rex sprockets are manufactured from super tough urethane. This material was selected because it is harder than most other available non-metallic sprocket materials and resists particle embedding. UHMW sprockets are not recommended for any application where dirt or other abrasives are present.

Sprockets

Rex polymeric chains are designed specifically for applications where corrosion resistance is desired. The current line of polymeric sprockets compliments the product line by offering additional corrosion resistance components. There are, however, situations that require metallic sprockets.

If a decision is made to use steel or cast sprockets, it is imperative to carefully inspect the sprocket for any unusual burrs, ridges, or protrusions and remove them before they come in contact with the polymeric chain. Such abrasive components have the capability of severely reducing the expected service life of the chain.

Flammability

Rex polymeric material will burn and support combustion. Acetal thermoplastics will burn with a clear flame and little smoke. Care should be taken to keep chain and accessories away from heat sources. Do not weld around conveyors or machinery without taking care to protect polymeric materials.

Ultra-Violet (UV) Resistance

Exposure to ultra-violet light can degrade polymeric chain materials. Special UV stabilized materials are available for outdoor application in direct sunlight.

Wear Strips

Metal Wear Strips

Metal wear strips are harder than non-metallics and, in addition, can be heat treated or work hardened to increase hardness. They are, therefore, suited for applications where abrasive particles are present either from the environment or from the products carried. Abrasive particles are less likely to imbed in metal wear strips.

For non-corrosive environments, plain carbon steel, cold finished, is recommended. For corrosive environments, use stainless steel, one quarter temper minimum (25R_C) cold finish.

■ DESIGN AND SELECTION

Wear Strips – (Cont'd.)

Steel

Plain carbon, cold rolled steel is recommended. Surface finish should be 32-63 RMS. Use heat treatable grades where available and hardened to 25-30R_C. Lubricants used should have rust inhibitors added.

Stainless Steel

Cold rolled finish (32-63 RMS) is recommended. An austenitic grade offers the best corrosion resistance.

The softer annealed grades of austenitic stainless steel are **not recommended**. Interaction between the chain material and the soft stainless steel might develop. When this happens, the resulting wear debris consists almost entirely of finely divided stainless steel particles, nearly black in color, similar to molybdisulfide or graphite. The wear of the stainless steel might be rapid while the thermoplastic chain by contrast exhibits only slight wear.

Therefore, **one quarter temper minimum** austenitic grade stainless is recommended. Martensitic stainless steels can also be used. They offer excellent wear resistance when heat treated to 25-35R_C, but they are not as corrosion resistant as austenitic.

Aluminum

Not recommended due to poor wear resistance.

Non-Metallic Wear Strips

Non-metallic wear strips have a lower coefficient of friction than metals. They are generally easier to install and remove and provide for quieter operation. Nylatron is the preferred material, especially for dry operation at high load or high speed conditions around corners. Ultra high molecular weight polyethylene is also recommended for all well lubricated applications and some dry applications.

Acetal

Not recommended for use with acetal chains. It is best not to run identical plastics together.

Nylatron

Nylatron (nylon with molybdisulfide filler) is the preferred material for dry applications because of its low wear state and low friction. It is especially suited for dry operation on double flex chain corners.

Although nylatron is more stable in wet applications than most nylons, it will absorb moisture and expand. Therefore, room for expansion must be provided and fasteners must allow for movement.

Ultra High Molecular Weight Polyethylene (UHMWPE)

UHMWPE (molecular weight of at least 1.0 million) is recommended for both dry and wet applications on straight runs. It is also recommended for all well lubricated corners and non-lubricated corners where chain load and speed are low. It is **not recommended** for dry operation on corners where the chain load or speed are high. It is also **not recommended** for operation in environments where particulate matter is present and can embed in the UHMWPE, subsequently wearing the chain.

UHMWPE has a wear rate equivalent to nylon in non-lubricated applications. It is virtually unaffected by moisture and is more resistant to corrosive chemicals than nylon. It is not as rigid as cast nylon and may deflect when subjected to high loads from side-flexing chains.

Teflon

This material has perhaps the lowest coefficient of friction available in a plastic wear strip material. It is soft and tends to flow off the surface and is not practical as a wear strip material except in low load – low speed applications.

Lubricant Impregnated Wood

Suitable for dry applications where self-lubricating properties of the material are best utilized. Not recommended for abrasive conditions where particles may imbed in the surface and wear the chain.

Catenary Sag

Rex® polymeric chain conveyors should provide for proper amount of catenary sag to allow proper chain and sprocket interaction. Ample space should be provided for the catenary. If chain sag is excessive or increased due to wear, it should be adjusted to the proper amount of sag by removing links. If space does not permit catenary sag, consult Rexnord.

Rex polymeric chains should never be run tight. Attempting to operate the chain with too little catenary sag can result in excessively high chain tension, leading to rapid chain wear to chain breakage. For this reason, screw take-ups are not recommended.

World Class Customer Service

For more than 100 years, the dedicated people of Rexnord have delivered excellence in quality and service to our customers around the globe. Rexnord is a trusted name when it comes to providing skillfully engineered products that improve productivity and efficiency for industrial applications worldwide. We are committed to exceeding customer expectations in every area of our business: product design, application engineering, operations, and customer service.

Because of our customer focus, we are able to thoroughly understand the needs of your business and have the resources available to work closely with you to reduce maintenance costs, eliminate redundant inventories and prevent equipment down time.

Rexnord represents the most comprehensive portfolio of power transmission and conveying components in the world with the brands you know and trust.

Rexnord is a registered trademark of Rexnord Industries, LLC. All rights reserved.

