

Falk True Hold Low-Speed Backstops

Model E (Inch/Metric)

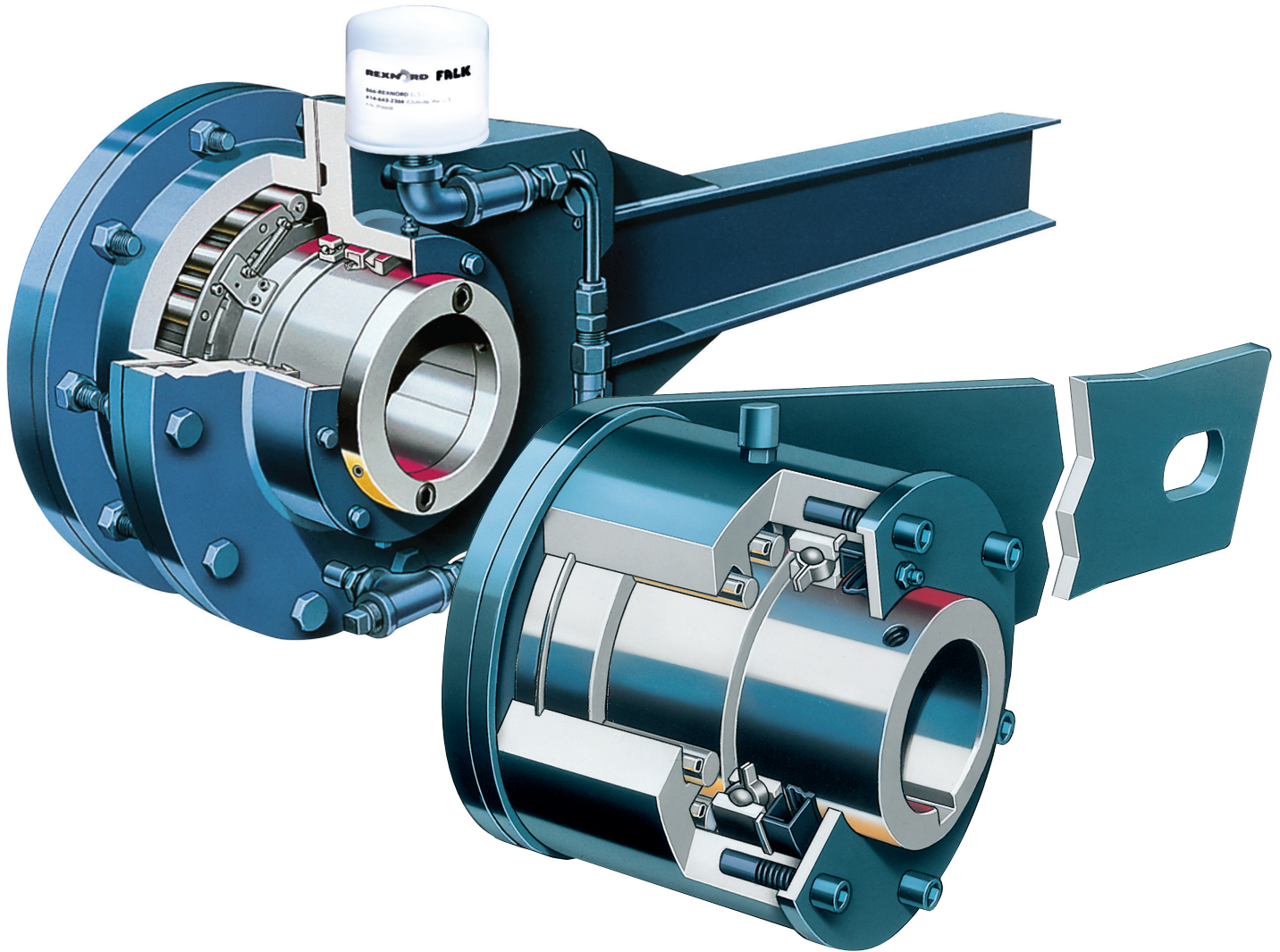

Falk True Hold Low-Speed Backstops



To learn more about the Falk® True Hold Low-Speed Backstops,
go to www.rexnord.com, where you'll find:

Product information • Brochures • Catalogs • Manuals

866-REXNORD/866-739-6673 (toll-free within the U.S.) or 414-643-2366 (Outside the U.S.)



Table of Contents

DESCRIPTION	PAGE
GENERAL INFORMATION	
Basic Information	3
How to Select Falk NRT & NRTH Backstops	4–5
Common Drive Arrangements	6
DIMENSIONS AND PART NUMBERS	
Type NRTH – Style B (L.S. Applications)	7
Type NRTH – Style C (H.S. Applications)	8
Type NRT (Inch)	9
Type NRT (Metric)	10
TECHNICAL DATA	
Backstop Operation	11–12
Service Parts	13
Engineering Recommendations	14–18
ORDERING & ADDITIONAL INFORMATION	
How to Order	19
Competitive Interchangeability Chart	20–22
Backstop Selection Procedure Definitions	23

Basic Information

Safety Notes

Install and operate Rexnord products in conformance with applicable local and national safety codes and per Rexnord installation manuals which are available upon request. Suitable guards for rotating members may be purchased from Rexnord as optional accessories. Refer to your local Rexnord district office for complete details.

WARNING: *Lock out power source and remove all external loads from gear drive system and from backstop before servicing drive or accessories. Locking out the power source and removing the load will reduce the possibility of an unexpected motion or reaction in the system.*

People Conveying Equipment — Selection of Rexnord products for applications whose primary purpose is the transportation of people is not approved. This includes such applications as freight or passenger elevators, escalators, man lifts, work lift platforms, ski tows, and ski lifts.

If the primary purpose of the application is material conveyance and occasionally people are transported, the Rexnord warranty may remain in effect provided the design load conditions are not exceeded and certification to the appropriate safety codes and load conditions has been obtained by the system designer or end user from the appropriate enforcement authorities.

Lubricants — Refer to Manuals 568-101, 568-102, 568-104, and 568-111 for a listing of transmission fluids, oils, and greases that meet Rexnord specifications.

Stored or Inactive Backstops — Backstops, sizes 1075-1185NRT are shipped without lubricant, with one ounce of Motorstor[Ⓢ] vapor phase rust inhibitor in the backstop that protects the internal parts against rust for a period of six months.

If the backstop (sizes 1075-1185) is to be stored or inactive for more than six months, add lubricant and Motorstor as recommended in the service manual for every additional six-month period. Indoor storage or a suitable covering is recommended.

Backstop, size 1045NRTH, Style B, is shipped with grease. If stored, rotate inner hub every two months to lubricate rotating elements.

Backstops, sizes 1055NRTH, 1065NRTH, and 1085NRTH, Style B, are shipped from the Rexnord factory filled to the proper level with oil. If stored, rotate inner hub every two months to lubricate rotating elements.

Backstops, sizes 1055 and 1065NRTH, Style C, are prelubricated and require no further maintenance of the working mechanism.

If an installed backstop is to remain inoperative for an extended period of time, remove the load before shutting down the equipment. Refer to service manual for complete instructions.

Ⓢ Product of the Daubert Chemical Company, Chicago, IL.

How to Select Falk TRUE HOLD NRT & NRTH Backstops — Imperial

(Refer to page 22 for explanation of terms and page 19 for how to order)

- Determine Drive Arrangements from page 6
 - Determine System Torque
 - Fig. 1 — Single motor, single backstop arrangements.
 - Fig. 2 — Tandem motor, single backstop arrangements.
 - Fig. 3 — Tandem motor, tandem backstop arrangements.
 - Figs. 4 and 5 — Refer these arrangements to the Rexnord factory for selection.
- Combine the horsepower from both motors for Fig. 2 and Fig. 3.
- System Torque = $\frac{5250 \text{ (MHP or BHP or LHP)}}{\text{rpm (rev/min)}}$
- MHP — Motor Nameplate HP
 BHP — Brake HP (calculated load). Use only if more than 75% of motor rating.
 LHP ① — Lift HP (calculated power to lift the load vertically. Use only if more than 75% of motor rating.)

① LHP can be calculated as follows:

$$\frac{\text{Short Tons Per Hour (TPH)} \times \text{Lift in Feet}}{990}$$

- Determine Required Backstop Torque
 - ② Required Backstop Torque =
 - System Torque (MHP, BHP, LHP) x Motor Maximum Torque (Stall or Breakdown Torque% ③)
 - 150%
 - ② For Figure 3 — Tandem motor, tandem backstop arrangements, select each backstop to hold 60% of the total required backstop torque.
 - ③ Use whichever is greater.
 - From pages 7 thru 9, select backstop with a torque rating equal to or greater than the required torque rating determined above.
 - Check the maximum bore, pages 7 thru 9. If a larger bore is required, select the next larger size or reduce shaft diameter.
 - Check the maximum overrunning speed from pages 7 thru 9. Refer to the Rexnord factory for higher speeds.
 - Check backstop reaction force at torque arm stirrup, Table 4, page 17.
 - Backstop and torque arm dimensions are listed on pages 7 thru 9; allow space for installation.
 - Only use keys furnished by the Rexnord factory.

If the backstop is mounted on the double-ended extension of the drive shaft, check shaft stresses and use dual path (safety lock) couplings or a minimum 2.0 service factor on the combined horsepower for the coupling on the NRT side.

Indexing requirements must be referred to the Rexnord factory for selection.

- NRTH Style B and NRTH Style C backstops are rated for more than 1,000,000 cycles of backstopping.
- NRT Backstops are rated for 100,000 backstopping cycles.
 If your application needs more than 100,000 load cycles, refer application to the Rexnord factory for selection.

Engineered Selection Method for Inclined Conveyors — It is possible to fine tune the selection and possibly consider the selection of a smaller size backstop, if detailed loading and conveyor profile information is furnished.

The following data is necessary:

- Power to lift the load (vertical)
- Power to move empty belt (friction)
- Power to move loaded belt horizontally (friction)

We can calculate these values if the following data is provided:

- Conveyor length (L) — feet
- Belt speed — fpm
- Short tons per hour — tph
- Total lift (H) — feet
- Belt width — inches
- Material weight — lb/ft³ (cubic ft)
- Pulley rpm (rev/min) or diameter — feet

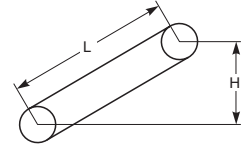

Selection Example

The selection examples below show the benefits gained from obtaining the required information to select by brake or lift torque vs. motor torque.

Steep Slope Conveyor	
200 Motor HP	
180 Brake HP	
150 Lift HP	
200% Stall	
68 rpm (rev/min)	
4.9375 Dia	
Motor HP and Stall % Known	
$\frac{200 \text{ MPH} \times 5250}{68 \text{ RPM}} \times \frac{200\%}{150} =$	
20,588 lb-ft Motor Torque	
Size 1095 NRT	
Brake HP Known	
$\frac{180 \text{ MPH} \times 5250}{68 \text{ RPM}} \times \frac{200\%}{150} =$	
18,529 lb-ft Brake Torque	
Size 1095 NRT	
Lift HP Known	
$\frac{150 \text{ MPH} \times 5250}{68 \text{ RPM}} \times \frac{200\%}{150} =$	
15,441 lb-ft Lift Torque	
Size 1085 NRT	

How to Select Falk TRUE HOLD NRT & NRTH Backstops — Metric

(Refer to page 22 for explanation of terms and page 19 for how to order)

- Determine Drive Arrangements from page 6
- Determine System Torque
 - Fig. 1 — Single motor, single backstop arrangements.
 - Fig. 2 — Tandem motor, single backstop arrangements.
 - Fig. 3 — Tandem motor, tandem backstop arrangements.
 - Figs. 4 and 5 — Refer these arrangements to the Rexnord factory for selection.

Combine the kilowatts from both motors for Fig. 2 and Fig. 3.

$$\text{System Torque} = \frac{9550 (\text{MkW or BkW or LkW})}{\text{rpm (rev/min)}}$$

MkW — Motor(s) Nameplate kW

BkW — Brake kW (calculated load). Use only if more than 75% of motor rating.

LkW ① — Lift kW (calculated power to lift the load vertically. Use only if more than 75% of motor rating.)

① LkW can be calculated as follows:

$$\frac{\text{Metric Tons Per Hour (TPH)} \times \text{Lift in Meter}}{367}$$

- Determine Required Backstop Torque

② Required Backstop Torque =

$$\frac{\text{System Torque} \times \text{Motor Maximum Torque (Stall or Breakdown Torque\%)} \text{ ③}}{150\%}$$

② For Figure 3 — Tandem motor, tandem backstop arrangements, select each backstop to hold 60% of the total required backstop torque.

③ Use whichever is greater.

- From pages 7, 8, or 10 select backstop with a torque rating equal to or greater than the required torque rating determined above.
- Check the maximum bore, pages 7, 8, or 10. If a larger bore is required, select the next larger size or reduce shaft diameter.
- Check the maximum overrunning speed from pages 7, 8, or 10. Refer to the Rexnord factory for higher speeds.
- Check backstop reaction force at torque arm stirrup, Table 4, page 17.
- Backstop and torque arm dimensions are listed on pages 7, 8, or 10; allow space for installation.
- Only use keys furnished by the Rexnord factory.

If the backstop is mounted on the double-ended extension of the drive shaft, check shaft stresses and use dual path (safety lock) couplings or a minimum 2.0 service factor on the combined horsepower for the coupling on the NRT side.

Indexing requirements must be referred to the Rexnord factory for selection.

- NRTH Style B and NRTH Style C backstops are rated for more than 1,000,000 cycles of backstopping.
- NRT Backstops are rated for 100,000 backstopping cycles.
If your application needs more than 100,000 load cycles, refer application to the Rexnord factory for selection.

Engineered Selection Method for Inclined Conveyors — It is possible to fine tune the selection and possibly consider the selection of a smaller size backstop, if detailed loading and conveyor profile information is furnished.

The following data is necessary:

- Power to lift the load (vertical)
- Power to move empty belt (friction)
- Power to move loaded belt horizontally (friction)

We can calculate these values if the following data is provided:

- Conveyor length (L) — meters
- Belt speed — (mpm)
- Metric tons per hour — tph
- Total lift (H) — meters
- Belt width — millimeters
- Material weight — Kg/M³ (cubic meter)
- Pulley rpm (rev/min) or diameter — meters

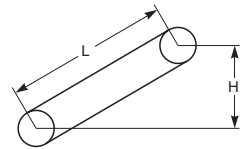

Selection Example

The selection examples below show the benefits gained from obtaining the required information to select by brake or lift torque vs. motor torque.

Steep Slope Conveyor	
150 Motor kW	
135 Brake kW	
115 Lift kW	
200% Stall	
68 rpm (rev/min)	
125 mm Dia	
Motor kW and Stall % Known	
$\frac{150 \text{ MkW} \times 9550}{68 \text{ RPM}} \times \frac{200\%}{150} =$	
28,088 Nm Motor Torque	
Size 1095 NRT	
Brake kW Known	
$\frac{135 \text{ BkW} \times 9550}{68 \text{ RPM}} \times \frac{200\%}{150} =$	
25,279 Nm Brake Torque	
Size 1095 NRT	
Lift kW Known	
$\frac{115 \text{ LkW} \times 9550}{68 \text{ RPM}} \times \frac{200\%}{150} =$	
21,534 Nm Lift Torque	
Size 1085 NRT	

Common Drive Arrangements

Figure 1 — Single motor, single backstop arrangements

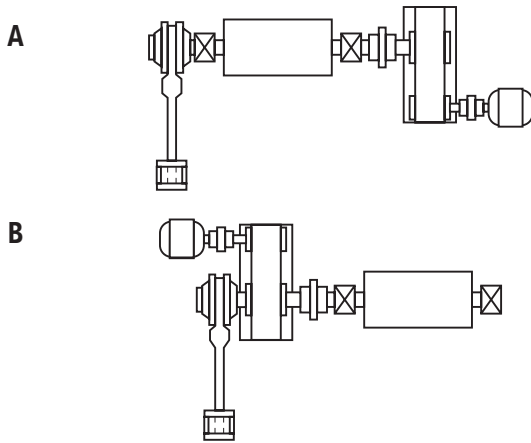

Figure 2 — Tandem motor, single backstop arrangements –
Select backstop to hold the **entire** system torque.

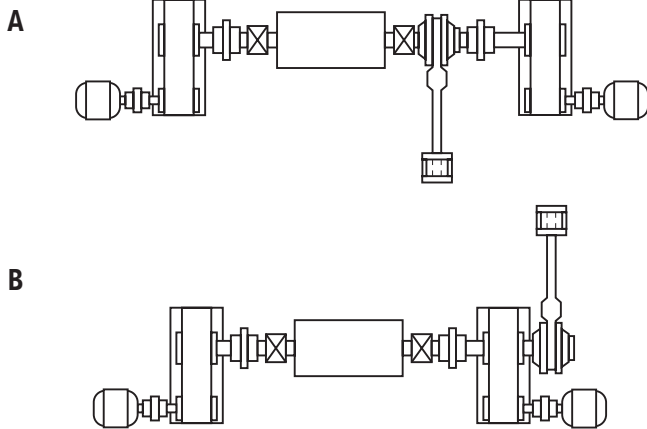
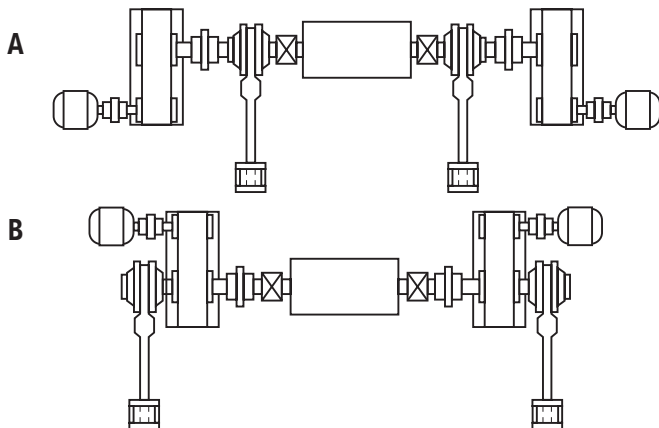

Figure 3 — Tandem motor, tandem backstop, single pulley arrangements –
Select each backstop to hold at least 60% of total system backstop torque.



For drive arrangements shown in Figures 4 & 5, engineered selections, indexing applications, vertical applications or for drive arrangements not shown, refer to the Rexnord factory for selection.

We will select a backstop for you if you furnish the following information:

- Drive arrangement
- Motor nameplate power
- Motor maximum torque as % of nameplate
- Headshaft rpm (rev/min), diameter, diameter tolerance, length, and key dimensions
- Duty cycle

If available, the following information when furnished may make it possible to select a smaller size backstop:

- Brake power
- Lift hp power

Figure 4 — Tandem motor, tandem backstop, dual pulley arrangement –
Refer to the Rexnord factory for selection.

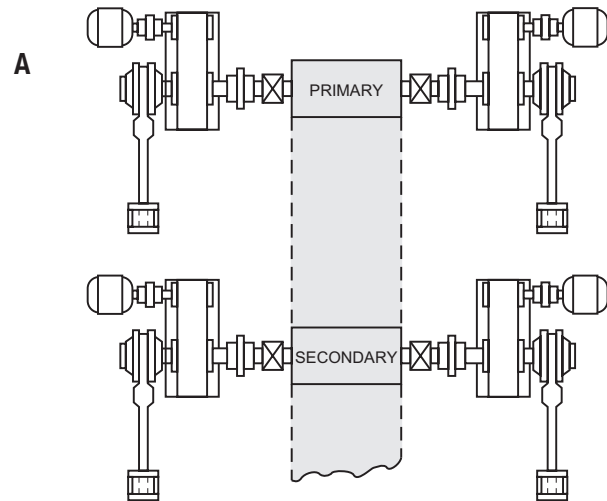
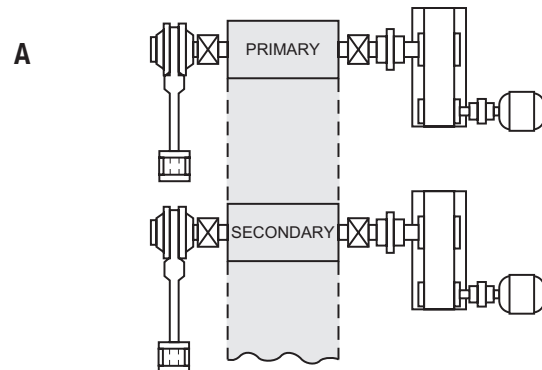
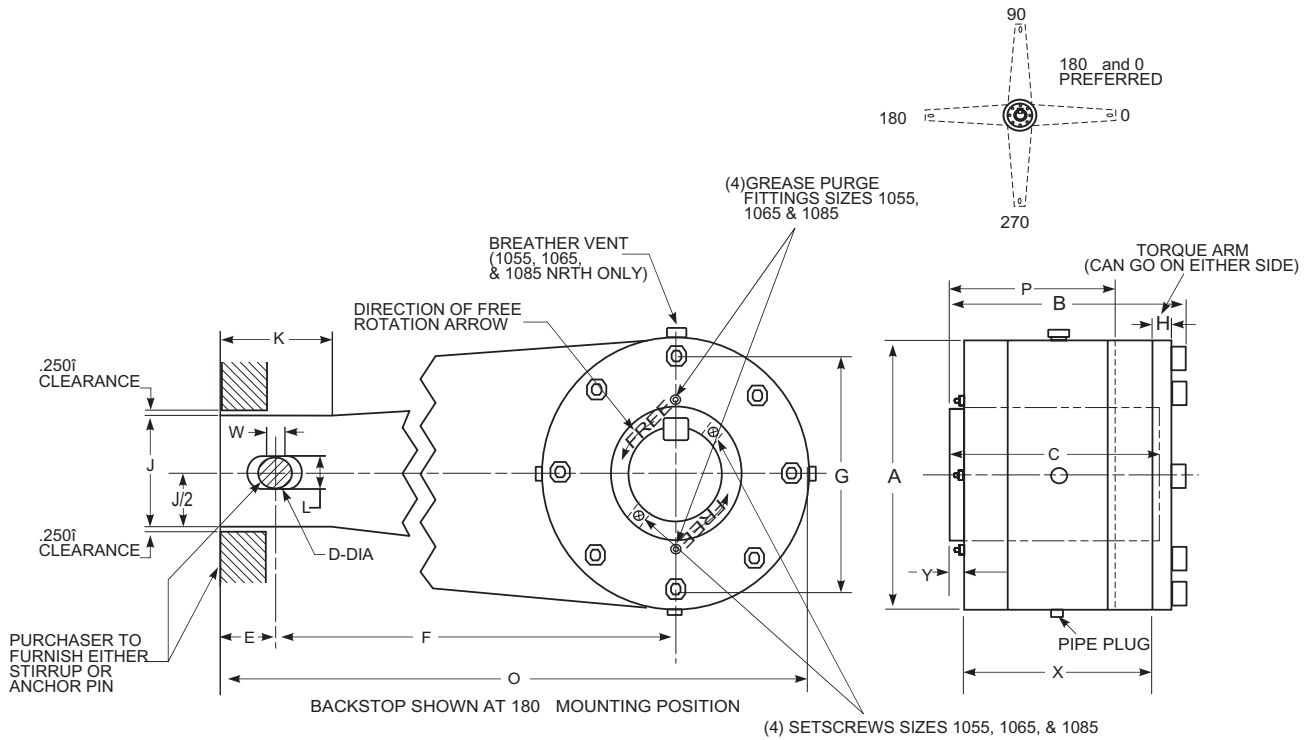

Figure 5 — Dual motor, dual backstop, dual pulley arrangement –
Refer to the Rexnord factory for selection.



Type NRTH – Style B (L.S. Applications)

Dimensions—Inch & Millimeter



Dimensions — Inch

Backstop Size	Torque Rating lb-ft	Max rpm	Bore ^①		A	B	C ^②	D ^③	E	F	G	H	J	K	L	X	W	Y	O	P ^④	Torque Arm Fasteners ^⑤	Wt ^⑥ lb
			Min	Max																		
1045 ^⑦	2,100	1800	1.75	2.50	6.50	4.19	3.50	0.656	1.25	7.00	5.75	0.375	2.50	1.50	0.78	3.38	0.06	11.50	2.62	(8) 3/8-24 X 1.0" LG	29	
1055 ^⑧	10,000	500	1.75	3.75	9.75	8.14	7.50	1.125	2.00	36.00	8.50	0.625	4.00	4.00	1.25	0.63	6.53	0.48	42.88	5.50	(8) 1/2-20 X 2.0" LG	157
1065 ^⑧	13,000	400	2.50	4.50	10.50	8.64	8.00	1.125	2.00	36.00	9.25	0.625	4.00	4.00	1.25	0.63	7.03	0.48	43.25	5.88	(8) 1/2-20 X 2.0" LG	190
1085 ^⑧	18,000	350	3.94	5.44	12.00	8.52	7.63	1.250	3.00	51.00	10.00	0.750	6.00	10.00	N/A	N/A	6.63	0.50	60.00	5.88	(10) 5/8-18 X 1.75" LG	260

Dimensions — Millimeter

Backstop Size	Torque Rating Nm	Max rpm	Bore ^①		A	B	C ^②	D ^③	E	F	G	H	J	K	L	X	W	Y	O	P ^④	Torque Arm Fasteners ^⑤	Wt ^⑥ lb
			Min	Max																		
1045 ^⑦	2,847	1800	44	64	165	106	89	17	32	178	146	10	64	38	20	18	86	2	292	67	(8) 3/8-24 X 1.0" LG	13.2
1055 ^⑧	13,557	500	44	95	248	207	191	29	51	914	216	16	102	102	32	16	166	12	1089	140	(8) 1/2-20 X 2.0" LG	71.2
1065 ^⑧	17,625	400	64	114	267	219	203	29	51	914	235	16	102	102	32	16	179	12	1099	149	(8) 1/2-20 X 2.0" LG	86.1
1085 ^⑧	24,403	350	100	140	305	216	194	32	76	1295	254	19	152	254	N/A	N/A	168	13	1524	149	(10) 5/8-18 X 1.75" LG	118.2

- ① Key is furnished by the Rexnord factory.
- ② Length through hub.
- ③ 1085NRTH – Hole for lifting purposes only.
- ④ Minimum shaft engagement for backstop support.
- ⑤ Fasteners are Hex Socket Head Cap Screws, Grade 8.
- ⑥ Weight shown is for backstop with minimum bore.
- ⑦ 1045NRTH backstops are shipped with lubriplate AERO NLGI #1/Grease Lubricant. 1045NRTH backstops require a keeper plate or retaining collars for axial retention.
- ⑧ 1055, 1065, and 1085NRTH backstops are shipped with lubricant (DEXRON). 1055, 1065, and 1085NRTH backstops are furnished with four radial holes and setscrews in the inner cam for axial retention on the shaft.

Mounting Positions — The backstop rotational axis must be horizontal within 5°.

The backstop and torque arm may be mounted at any desired angle. Horizontal or near horizontal mounting of the torque arm provides maximum bearing life.

Purchaser — The purchaser is responsible for assembling the backstop, air vent, and torque arm. A 125 micro-inch (3.2 micro-meters), or finer, shaft finish is recommended.

NOTE: Electronic drawings are available from the Rexnord website: www.rexnord.com

Type NRTH – Style C (H.S. Applications)

Dimensions—Inch & Millimeter

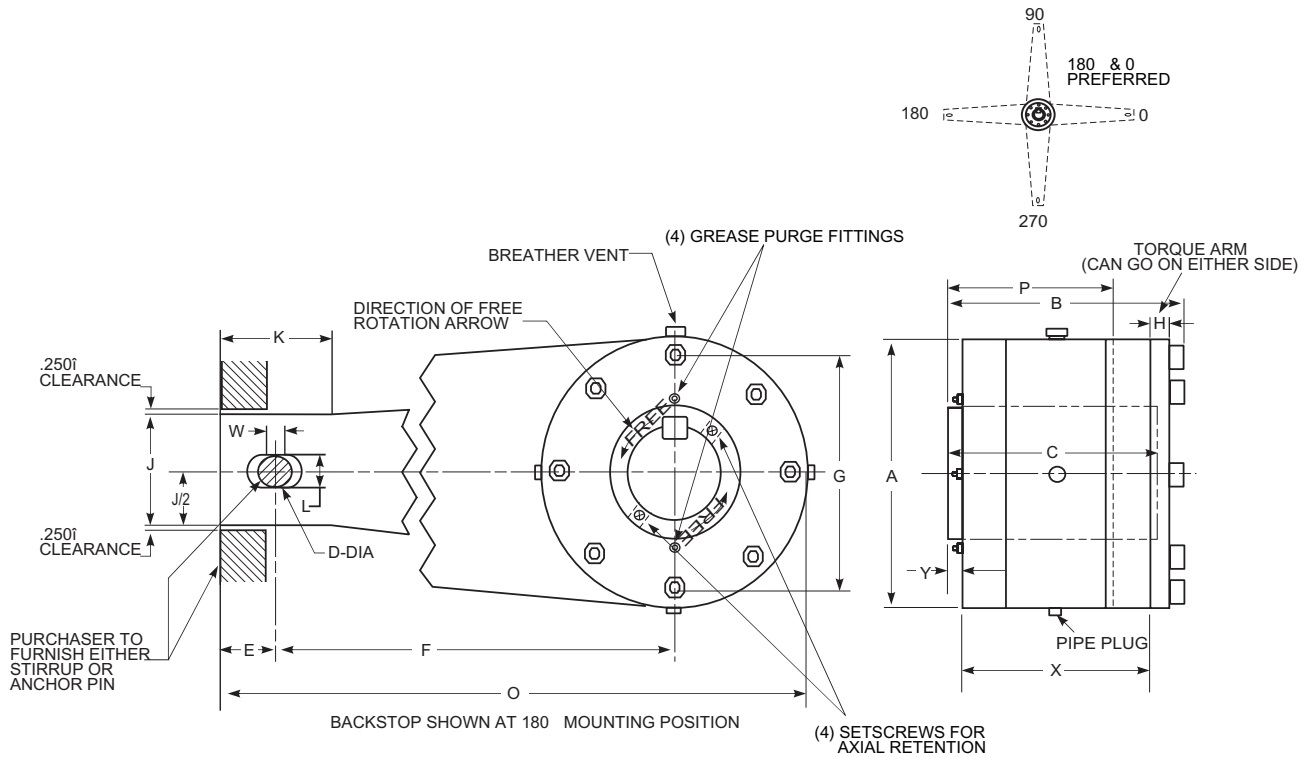

Dimensions — Inch

Backstop Size	Torque lb-ft	Speed Range		Bore ^①		A	B	C ^②	D	E	F	G	H	J	K	L	W	X	Y	O	P ^③	Torque Arm Fasteners ^④	Wt ^⑤ lb
		Min	Max	Min	Max																		
1055 ^⑥	5965	320	2100	1.75	3.75	9.75	8.14	7.50	1.125	2.00	36.00	8.50	0.625	4.00	4.00	1.25	0.63	6.53	0.48	42.88	5.50	(8) 1/2-20 X 2.0" LG	157
1065 ^⑥	11,388	250	1800	2.50	4.50	10.50	8.64	8.00	1.125	2.00	36.00	9.25	0.625	4.00	4.00	1.25	0.63	7.03	0.48	43.25	5.88	(8) 1/2-20 X 2.0" LG	190

Dimensions — Millimeter

Backstop Size	Torque lb-ft	Speed Range		Bore ^①		A	B	C ^②	D	E	F	G	H	J	K	L	W	X	Y	O	P ^③	Torque Arm Fasteners ^④	Wt ^⑤ lb
		Min	Max	Min	Max																		
1055 ^⑥	5965	320	2100	44	98	248	207	191	29	51	914	216	16	102	102	32	16	166	12	1089	140	(8) 1/2-20 X 2.0" LG	71.2
1065 ^⑥	11,388	250	1800	64	115	267	219	203	29	51	914	235	16	102	102	32	16	179	12	1099	149	(8) 1/2-20 X 2.0" LG	86.1

① Key is furnished by the Rexnord factory.

② Length through hub.

③ Minimum shaft engagement for backstop support.

④ Fasteners are Hex Socket Head Cap Screws, Grade 8.

⑤ Weight shown is for backstop with minimum bore.

⑥ Style C, size 1055 and 1065NRTH backstops are shipped permanently lubricated, no additional lubrication or re-lubrication is required. Grease fittings for optional purging of seals are provided.

Mounting Positions — The backstop rotational axis must be horizontal within 5°.

The backstop and torque arm may be mounted at any desired angle. Horizontal or near horizontal mounting of the torque arm provides maximum bearing life.

Purchaser — The purchaser is responsible for assembling the backstop, air vent, and torque arm. A 125 micro-inch (3.2 micro-meters), or finer, shaft finish is recommended.

Type NRT

Dimensions—Inch

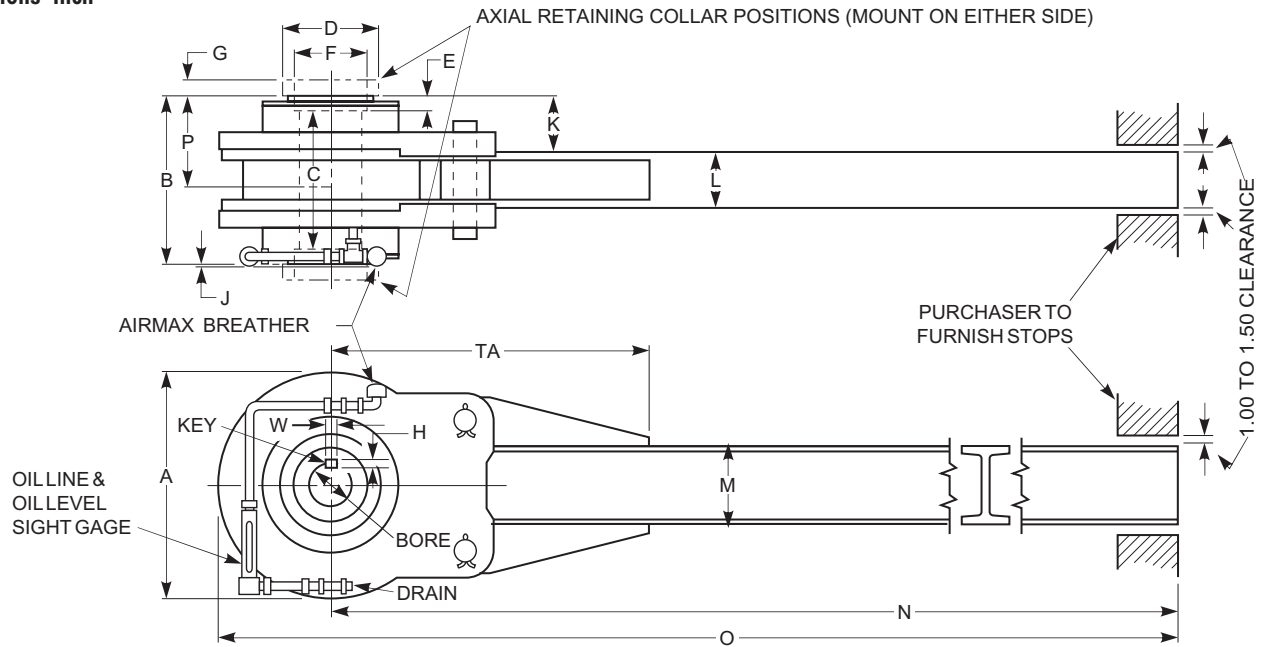

For Bore and Keyway Sizes and Tolerances, Refer to Page 17

Backstop Size ^①	Torque Rating (lb-ft)	Max ^② Over-running Speed (rpm)	Bore ^③		A	B	C	D	E	F ^④	G ^⑤	J Max	K	L	M	N	O	P ^⑤	TA Max	Wt ^⑥ lb
			Min ^② (in)	Max ^② (in)																
1075NRT	10,000	450	2.31	3.94	11.6	8.4	7.6	5.00 ^⑦	.40	3.96	.70	2.40	2.8	2.8	4.0	36.0	41.8	6.2	15.87	155
1085NRT	16,000	350	2.94	5.19	14.1	8.4	7.6	6.50 ^⑧	.40	5.21	.70 ^⑧	3.62	2.6	3.0	5.0	48.0	55.1	6.2	24.62	270
1095NRT	28,000	300	3.44	5.50	15.4	10.6	9.8	7.20	.40	5.91	.80	3.20	3.5	3.6	6.0	54.0	61.7	8.1	25.70	390
1105NRT	45,000	180	4.94	7.44	19.3	10.6	9.8	9.20 ^⑨	.40	8.50	1.00 ^⑩	2.70	3.2	4.1	8.0	66.0	75.7	8.1	25.40	620
1115NRT	75,000	150	5.94	8.44	21.5	11.6	10.6	10.50 ^⑩	.50	9.25	1.24	3.00	3.5	4.6	10.0	72.0	82.8	9.0	27.39	870
1125NRT	105,000	135	7.25	9.00	24.5	12.2	11.2	12.12	.50	11.00	1.24	3.16	3.6	5.0	12.0	78.0	90.3	9.6	29.60	1130
1135NRT	150,000	125	8.50	10.50	27.0	14.0	13.0	13.60	.50	10.52	1.24	2.60	4.3	5.5	12.0	82.0	95.5	11.4	32.59	1460
1145NRT	212,000	115	9.00	12.00	31.0	14.0	13.0	14.94	.50	12.02	1.24	1.62	4.2	5.6	15.0	88.0	103.5	11.4	36.90	1880
1155NRT	249,000	100	10.50	13.25	35.0	14.3	13.3	17.40	.50	13.27	1.50	1.94	4.1	6.0	18.0	94.0	111.5	11.5	42.15	2670
1165NRT	346,000	85	12.50	15.50	37.2	16.6	15.6	19.80	.50	15.52	2.00	2.54	4.8	6.3	20.0	100.0	118.6	13.8	60.85	3120
1175NRT	519,000	80	13.50	17.50	43.6	17.4	16.4	23.00	.50	17.52	2.00	2.60	5.1	7.3	24.0	120.0	141.8	14.3	51.08	4800
1185NRT	747,000	70	15.50	20.00	50.0	18.0	17.0	24.90	.50	20.02	2.00	2.44	4.0	10.1	27.2	120.0	145.0	14.7	52.15	6625

- ① Dimensions are for reference only and are subject to change without notice unless certified.
- ② Refer to the Rexnord factory for higher maximum overrunning speeds or for bores outside of listed range.
- ③ Key is furnished by the Rexnord Factory.
- ④ Counterbore is for manufacturing.
- ⑤ Dimension G is the retaining collar thickness for one collar. Size 1075 bores 3.50" and over, Size 1085 bores 4.75" and over, Size 1105 bores 7.00" and over, and Size 1115 bores over 8.00" require two collars (one on each side) or one collar with a step in the shaft. Check usable shaft length if two (2) collars are used.

- ⑥ Weight shown is for backstop with minimum bore and without oil.
- ⑦ Size 1075 with bores over 3.4375", D = 6.50".
- ⑧ Size 1085 with bores over 4.75", D = 7.20", G = .80".
- ⑨ Size 1105 with bores over 6.9375", D = 10.50", G = 1.24".
- ⑩ Size 1115 with bores over 8.00", D = 12.12"

Purchaser — The purchaser is responsible for assembling the backstop retaining collar (when furnished), oil line, oil level sight gauge, air vent, and for furnishing the oil and the torque arm stirrup per the Rexnord service manual 568-111. A 125 micro-inch, or finer, shaft finish is recommended.

Mounting Positions — The backstop rotational axis must be horizontal within $\pm 5^\circ$.

The backstop and torque arm may be mounted at any desired angle, but the position must be specified to permit furnishing of oil lines to suit the mounting. Horizontal or near horizontal mounting of the torque arm provides maximum bearing life.

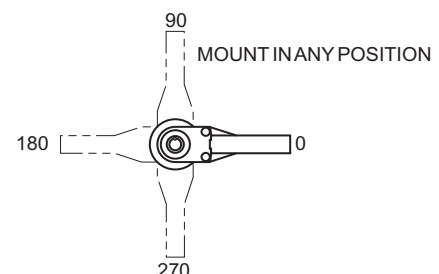

NOTE: Electronic drawings are available from the Rexnord website: www.rexnord.com

Backstop Operation — NRT

Overrunning

Figure 6 — For most of its operating life, a backstop is in the overrunning mode of operation.

The rollers, roller cage, and stop lugs rotate with the inner cam as a unit since they are connected by the energizing springs.

The outer race does not rotate since it is bolted to the end covers, which are held by the backstop torque arm.

Figure 7 — While overrunning, the rollers roll on the outer race and slide on the inner cam ramps. Friction and centrifugal force tend to lift the rollers off the cam, minimizing contact and wear.

Figure 6

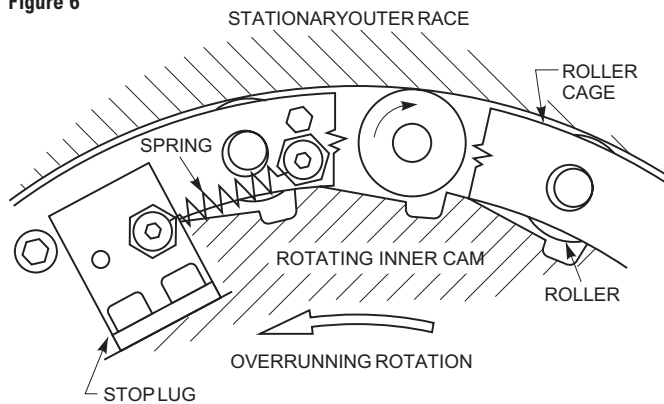
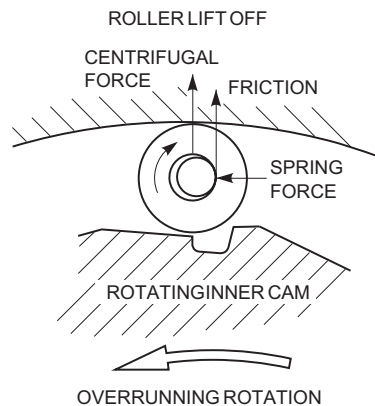

Figure 7



The energizing springs stretch during overrunning to provide tension to the roller cage assembly (Figure 6). This tension keeps the rollers ready for instantaneous backstopping engagement and minimizes the relative rotation of the roller cage to the inner cam.

The stop lugs axially position the roller cage assembly on the inner cam. They also prevent the roller cage from rotating too far, which would cause the rollers to strike the upright side of the adjacent ramp. Maximum relative rotation of the roller cage assembly and inner cam during overrunning is limited by the stop lugs.

Backstopping

Figure 8 — As the rotating shaft stops and attempts to reverse, the inner cam is instantly stopped by the wedging action of the rollers in the annular openings between the cam ramps and outer race.

From the outer race, the backstopping torque is carried through the end covers to the torque arm and the adjoining superstructure.

Figure 9 — All rollers are engaged simultaneously since they are positioned by the spring-loaded roller cage.

Load division between the rollers is assured by machining accuracy of the inner cam ramps, rollers, roller cage, and outer race.

Figure 8

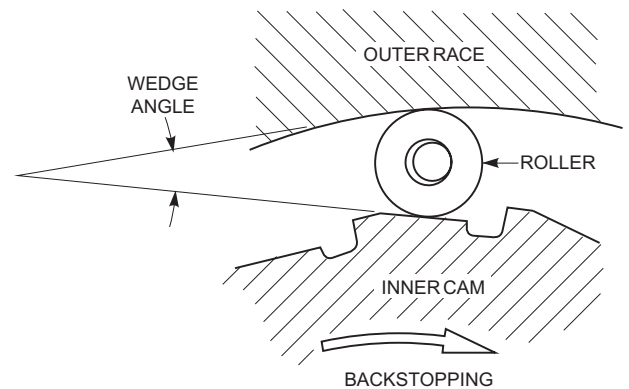
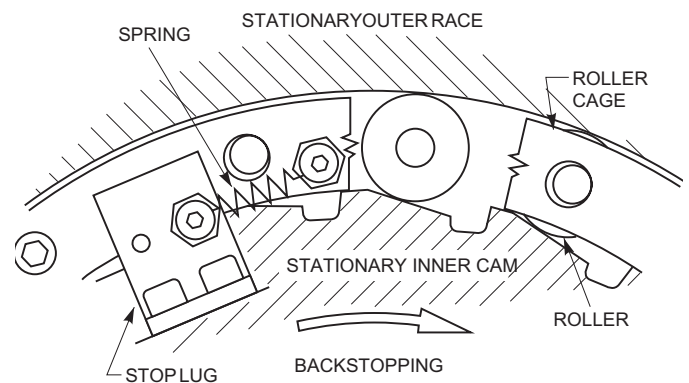

Figure 9



As additional backstopping torque is applied to the inner cam, the rollers will tend to move deeper into the wedging position, thereby increasing the resistance to slippage. Relative rotational movement between initial backstopping engagement at no load to backstopping at full catalog rating is approximately 3° maximum.

The torque capacity of the backstop is based on the tangential friction resistance force at the outer race developed by the compressive force between the inner cam ramps, rollers, and outer race.

The maximum torque capacity of the backstop is limited by the Hertzian contact stress at inner cam/roller and roller/outer race contact points, bending strength of torque arm, and hoop stress of outer race.

Backstop Operation — NRT Styles B and C

The NRT styles B and C backstops are an addition to the Rexnord line of roller-ramp backstops. These backstops operate on the proven principal of sprag technology, which has been around since the mid 1950s. The sprag technology has advanced over the years with improvements in materials and heat treatment processes.

NRT Style B

The NRT Style B backstops are designed for lower operating speed applications. The design features three primary components: a cylindrical inner race, a cylindrical outer race, and a sprag cage consisting of a full complement of individually tensioned sprags.

The proprietary geometry of the sprags allows for the one-way operation of the backstop (see Figure 10). During normal operation of the backstop, the inner race rotates in the free direction while the outer race remains stationary. During an attempted reversal of the backstop, torque is instantly transmitted from the inner race, through the sprags, to the outer race, which is held stationary with a torque arm. The features of the backstops are zero backlash, large bore capacity, large torque capacity and grease purge cavities on sizes 1055, 1065, and 1085.

NOTE: If all the upgraded features of the NRT style backstop are not required, then consider the 1055, 1065, and 1085 NRT Style B backstops as a less expensive alternative to the NRT backstop design.

Figure 10

(1055, 1065, and 1085 ONLY)

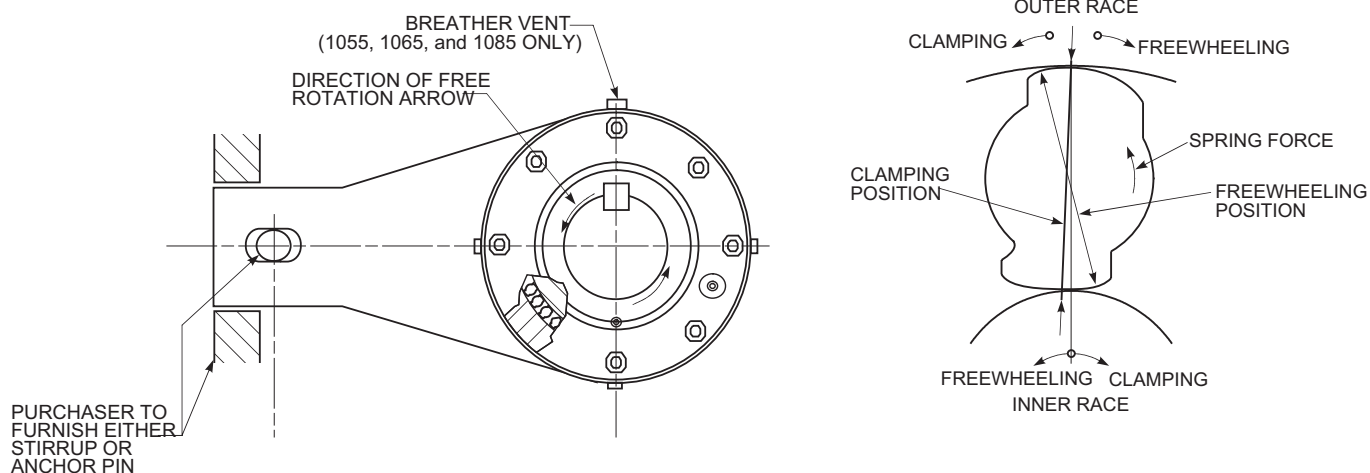

NRT Style C

The NRT Style C backstops are offered in sizes 1055 and 1065, and are designed for a higher operating speed than the Style B. The centrifugal lift-off sprag is a feature exclusive to the NRT Style C design in the NRT family of Rexnord backstops. This feature incorporates a special sprag design with an offset center of gravity. During overrunning, centrifugal force, F_c , causes the individually tensioned sprags to lift off the outer race, thereby allowing the sprags to operate without wear (Figure 11). When the overrunning

speed of the backstop has reduced sufficiently so that the centrifugal force is less than the spring force, the sprags will return to their contact positions and stand ready to transmit torque without backlash (Figure 12). Special features are increased service life, reduced heat generated, high overrunning speeds, and sealed for life design (minimum maintenance).

Figure 11

OVERRUNNING (LIFT OFF)

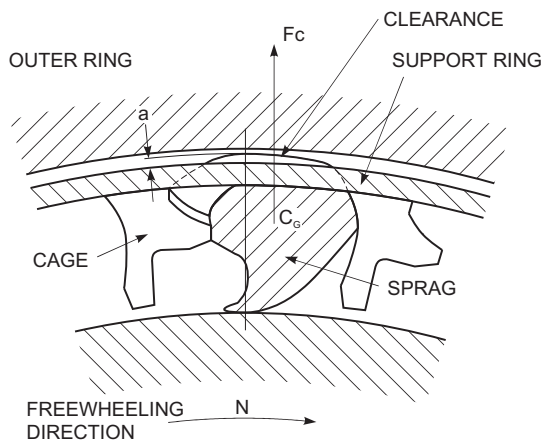
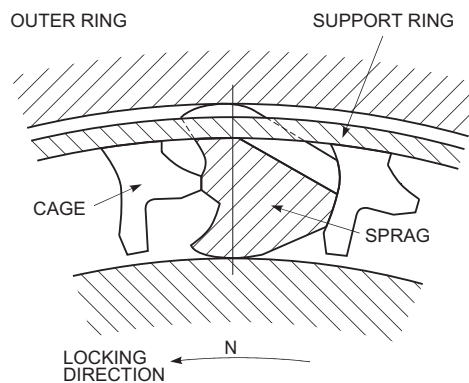

Figure 12

BACKSTOPPING



Service Parts (Type NRT Backstops)

INTRODUCTION — Give complete data shown on the backstop nameplate and name of parts required. Complete data will assure receipt of the correct parts.

COVER GASKETS — When end covers are removed to replace oil seals, order new cover gaskets to prevent oil leakage.

Type NRT — Backstop Parts

Part Description
Lubrication Assembly ^①
Air Vent Assembly
Oil Level Gauge
Torque Arm
Oil Seal (each)
Cover Fasteners (set) ^②
Cover Gasket (each)

① Assembly shown includes sight gauge, air vent, and all piping, tees, and elbows required.

② Cover fastener; two sets are required per backstop.

PART DESCRIPTIONS

1. End Cover	7. Roller Cage End Rings (2)	11. Optional Axial Retaining Collar with fasteners	13. Stop Lug Fasteners
2. Gasket	8. Inner Cam	12. Stop Lug	14. Rotation Direction Plate
3. Bearing	9. Outer Race		15. End Cover Fasteners
4. Outer Seal	10. Labyrinth Cover (2)		16. Torque Arm
5. Inner Seal			17. Torque Arm Pin
6. Rollers			18. Roller Cage Spacer Post
			19. Roller Cage Fasteners
			20. Grease Fitting

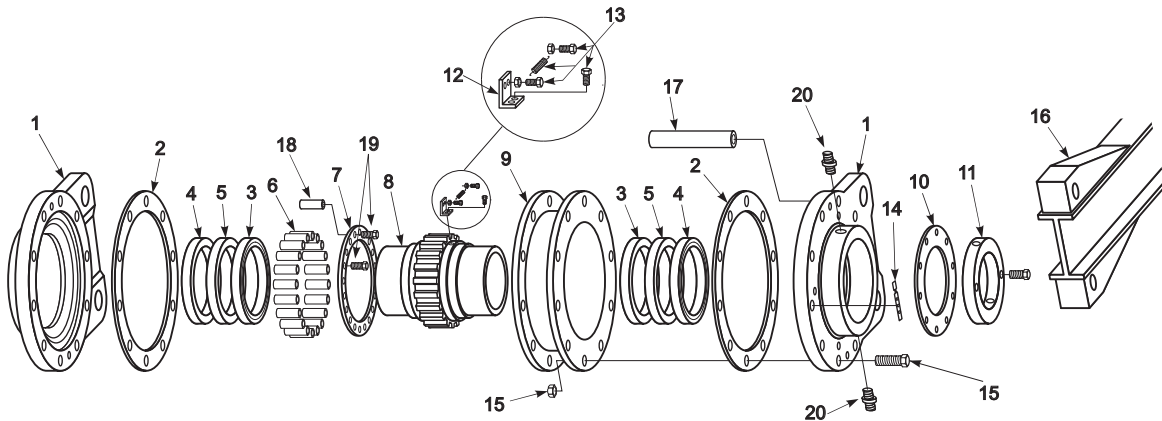

Dismantling, Repair, & Parts Replacement

WARNING: DO NOT attempt to service or remove backstop before removing load.

An important part of the Falk NRT backstop manufacturing process is the full load and overrunning testing with specially instrumented equipment. Consequently, return NRT backstops to Rexnord for repair and full load testing.

Except for replacement of oil seals (Service Manual 568-131), NRT backstops should not be dismantled or repaired in the field. If seals are to be replaced, it is important that the cam and roller assemblies not be removed from the outer race. Removal will void applicable warranties.

When contacting Rexnord Service Parts Department concerning required service, state the nature of the problem and give complete data from backstop nameplate, order number, size, date, etc.

Contact: gear.service.parts@rexnord.com

Engineering Recommendations

Backstop Applications — Falk NRT and NRTH backstops are designed to prevent reverse rotation in applications such as inclined conveyors, bucket elevators, fans, rotary pumps, and kilns. If local safety codes permit, the backstop may be used as a backup for a brake on those applications, but NOT in people conveying systems such as elevators, manlifts, ski tows or ski lifts. Also, DO NOT use the backstop as a substitute for a brake.

Indexing — Falk NRT and NRTH backstops can be used for indexing service, provided there is one complete revolution of the backstop between backstopping cycles. Refer application data to the Rexnord factory for selection.

Safety Standards — The backstop and normal associated equipment (shaft, pulleys, etc.) involve moving parts; therefore, consult local, state, OSHA, and ANSI safety codes for proper guarding of revolving parts and possible pinch points (a pinch point occurs at the contact point between the backstop torque arm and support, and between the torque arm and stirrup).

Chemical Atmospheres — The backstop may be damaged if exposed to certain types of chemicals or vapors; for example: potash dust, chlorine gas, carbon tetrachloride, etc. These materials may cause deterioration of the seals or aluminum roller cage rings.

Driven Shaft — It is the purchaser's responsibility that the driven shaft is designed and engineered to withstand all bending and torque loads generated by the NRT.

Lubricant — DO NOT USE EXTREME PRESSURE LUBRICANTS OR GREASES. Typical extreme pressure additives are sulphur, chlorine, lead and phosphorus derivatives, as well as graphite and molybdenum disulfide, which act under conditions of heat and pressure to produce a coating on the working surfaces.

Operating Temperature — Enclosure of the backstop may cause overheating. Provide adequate ventilation. Backstop operating temperatures, at maximum overrunning speed, may reach 200°F (93°C). Determine the effect of this temperature on the driven equipment and provide cooling if necessary.

If a backstop operates in the sun at ambient temperatures over 100°F (38°C), then special measures should be taken to protect the backstop from solar energy. This protection can consist of a canopy over the backstop or reflective paint on the backstop. If neither is possible, a cooling device such as a fan may be required to prevent the sump temperature from exceeding the allowable maximum of 200°F (93°C).

Keys & Keyways — Keys used with NRT and NRTH backstops are furnished by the Rexnord factory. Keys are either mild steel, cold drawn 1045 steel or heat treated alloy steel (310-350 HB). Use only those keys provided by the Rexnord factory (see Table 1).

Do not use sled runner type keyway. It may induce undue forces on backstop.

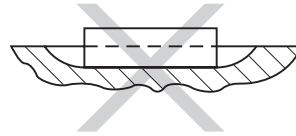

Engineering Recommendations

Table 1 — Shaft and Keyway Dimensions — Inch^①

Backstop Size	Nominal Shaft Diameter (Over-Thru)	Shaft Keyway		Backstop Keyway		Key			
		Width	Depth	Width	Depth	Width x Height	Key Length Furnished	Minimum Key Engagement	Key ^② Material ^③
1045NRT	1.3750 - 2.2500	0.500	0.250	0.500	0.250	0.500 x 0.500	3.500	2.625	3
	2.2500 - 2.5000	0.625	0.313	0.625	0.125	0.625 x 0.438	3.500	2.625	3
1055NRT	1.7500 - 2.2500	0.500	0.250	0.500	0.250	0.500 x 0.500	7.500	5.500	3
	2.2500 - 2.7500	0.625	0.313	0.625	0.313	0.625 x 0.625	7.500	5.500	3
	2.7500 - 3.2500	0.750	0.375	0.750	0.375	0.750 x 0.750	7.500	5.500	3
	3.2500 - 3.7500	0.875	0.438	0.875	0.438	0.875 x 0.875	7.500	5.500	3
1065NRT	2.5000 - 2.7500	0.625	0.313	0.625	0.313	0.625 x 0.625	8.000	5.875	3
	2.7500 - 3.2500	0.750	0.375	0.750	0.375	0.750 x 0.750	8.000	5.875	3
	3.2500 - 3.7500	0.875	0.438	0.875	0.438	0.875 x 0.875	8.000	5.875	3
	3.7500 - 4.0000	1.000	0.500	1.000	0.500	1.000 x 1.000	8.000	5.875	3
	4.0000 - 4.5000	1.000	0.500	1.000	0.250	1.000 x 0.750	8.000	5.875	3
1085NRT	3.9375 - 4.5000	1.000	0.500	1.000	0.500	1.000 x 1.000	7.625	5.875	3
	4.5000 - 4.7500	1.250	0.625	1.250	0.625	1.250 x 1.250	7.625	5.875	3
	4.7500 - 5.4375	1.250	0.625	1.250	0.313	1.250 x 0.938	7.625	5.875	3
1075NRT	2.3125 - 2.7500	.625	.313	.625	.313	.625 x .625	7.25	6.50	2
	2.7500 - 3.2500	.750	.375	.750	.375	.750 x .750	7.00	6.00	1
	3.2500 - 3.5625	.875	.438	.875	.438	.875 x .875	5.50	4.50	1
	3.5625 - 3.7500	.875	.313	.875	.323	.875 x .625	7.25	5.50	1
	3.7500 - 3.9375	1.000	.500	1.000	.250	1.000 x .750	7.00	6.50	1
	2.9375	.750	.375	.750	.375	.750 x .750	7.50	7.00	2
1085NRT	2.9375 - 3.2500	.750	.375	.750	.375	.750 x .750	7.50	7.00	2
	3.2500 - 3.7500	.875	.438	.875	.438	.875 x .875	6.00	5.50	2
	3.7500 - 4.5000	1.000	.500	1.000	.500	1.000 x 1.000	7.00	5.50	1
	4.5000 - 4.7500	1.250	.625	1.250	.625	1.250 x 1.250	7.00	4.00	1
	4.7500 - 5.1875	1.250	.625	1.250	.250	1.250 x .8750	7.00	7.00	1
1095NRT	3.4375	.875	.438	.875	.438	.875 x .875	9.50	9.00	2
	3.4375 - 3.7500	.875	.438	.875	.438	.875 x .875	9.50	9.00	2
	3.7500 - 4.5000	1.000	.500	1.000	.500	1.000 x 1.000	9.00	8.50	1
	4.5000 - 5.0000	1.250	.625	1.250	.625	1.250 x 1.250	7.00	6.00	1
	5.0000 - 5.5000	1.250	.625	1.250	.500	1.250 x 1.125	7.00	6.50	1
1105NRT	4.9375	1.250	.625	1.250	.625	1.250 x 1.250	7.50	7.00	2
	4.9375 - 5.5000	1.250	.625	1.250	.625	1.250 x 1.250	7.50	7.00	2
	5.5000 - 6.5000	1.500	.750	1.500	.750	1.500 x 1.500	8.00	6.50	1
	6.5000 - 7.4375	1.750	.750	1.750	.750	1.750 x 1.500	9.00	5.50	1
1115NRT	5.9375	1.500	.750	1.500	.750	1.500 x 1.500	8.75	8.00	2
	5.9375 - 6.5000	1.500	.750	1.500	.750	1.500 x 1.500	8.75	8.00	2
	6.5000 - 7.5000	1.750	.750	1.750	.750	1.750 x 1.500	9.00	8.50	1
	7.5000 - 8.0000	2.000	.750	2.000	.750	2.000 x 1.500	9.00	8.00	1
	8.0000 - 8.4375	2.000	.750	2.000	.500	2.000 x 1.250	10.50	10.50	1
1125NRT	7.2500	1.750	.750	1.750	.750	1.750 x 1.500	11.00	10.50	1
	7.2500 - 7.5000	1.750	.750	1.750	.750	1.750 x 1.500	11.00	10.50	1
	7.5000 - 9.0000	2.000	.750	2.000	.750	2.000 x 1.500	11.00	10.50	1
1135NRT	8.5000	2.000	.750	2.000	.750	2.000 x 1.500	11.00	10.00	2
	8.5000 - 9.0000	2.000	.750	2.000	.750	2.000 x 1.500	11.00	10.00	2
	9.0000 - 10.5000	2.500	.875	2.500	.875	2.500 x 1.750	12.00	11.00	1
1145NRT	9.0000	2.000	.750	2.000	.750	2.000 x 1.500	13.00	12.50	2
	9.0000 - 11.0000	2.500	.875	2.500	.875	2.500 x 1.750	12.00	11.50	2
	11.0000 - 12.0000	3.000	1.000	3.000	1.000	3.000 x 2.000	13.00	11.00	1
1155NRT	10.5000	2.500	1.250	2.500	1.250	2.500 x 2.500	12.00	11.00	2
	10.5000 - 11.0000	2.500	1.250	2.500	1.250	2.500 x 2.500	12.00	11.00	2
	11.0000 - 13.0000	3.000	1.000	3.000	1.000	3.000 x 2.000	13.00	12.50	2
	13.0000 - 13.2500	3.500	1.250	3.500	1.250	3.500 x 2.500	12.00	9.00	2
1165NRT	12.5000	3.000	1.000	3.000	1.000	3.000 x 2.000	15.50	12.00	2
	12.5000 - 13.0000	3.000	1.000	3.000	1.000	3.000 x 2.000	15.50	12.00	2
	13.0000 - 15.0000	3.500	1.250	3.500	1.250	3.500 x 2.500	12.00	12.00	2
	15.0000 - 15.5000	4.000	1.500	4.000	1.500	4.000 x 3.000	13.00	9.00	2
1175NRT	13.5000	3.500	1.250	3.500	1.250	3.500 x 2.500	16.00	15.50	2
	13.5000 - 15.0000	3.500	1.250	3.500	1.250	3.500 x 2.500	16.00	15.50	2
	15.0000 - 17.5000	4.000	1.500	4.000	1.500	4.000 x 3.000	13.00	12.50	2
1185NRT	15.5000	4.000	1.500	4.000	1.500	4.000 x 3.000	17.00	16.50	2
	15.5000 - 18.0000	4.000	1.500	4.000	1.500	4.000 x 3.000	17.00	16.50	2
	18.0000 - 20.0000	5.000	1.750	5.000	1.750	5.000 x 3.500	14.00	13.50	2

① Backstop supplied with H7 bore assuming h6 shaft (ANSI tolerance specification). Backstop key and keyway tolerance per Table 5 page 17, assuming shaft keyway per ANSI B17.1

② Number 1 keys are cold drawn 1045 steel. Number 2 keys are heat-treated alloy steel (310 - 350 HB). Number 3 keys are mild steel.

③ Keys are furnished by Rexnord to suit shaft and backstop keyways. Keys are either cold drawn 1045 or heat-treated alloy steel (310 - 350 HB). Only use keys furnished by the Rexnord factory. Shaft keyway depth tolerance of -.000" -.010" is recommended.

Engineering Recommendations

Table 1A — Shaft and Keyway Dimensions — Millimeter^①

Backstop Size	Nominal Shaft Diameter (Over-Thru)	Shaft Keyway		Backstop Keyway		Key			
		Width	Depth	Width	Depth	Width x Height	Key Length Furnished	Minimum Key Engagement	Key ^② Material ^③
1045NRTH	44 - 50	14.0	5.5	14.0	3.8	14 x 9	88.9	66.7	3
	50 - 58	16.0	6.0	16.0	4.3	16 x 10	88.9	66.7	3
	58 - 64	18.0	7.0	18.0	2.3	18 x 9	88.9	66.7	3
1055NRTH	44 - 50	14.0	5.5	14.0	3.8	14 x 9	190.5	139.7	3
	50 - 58	16.0	6.0	16.0	4.3	16 x 10	190.5	139.7	3
	58 - 65	18.0	7.0	18.0	4.4	18 x 11	190.5	139.7	3
	65 - 75	20.0	7.5	20.0	4.9	20 x 12	190.5	139.7	3
	75 - 85	22.0	9.0	22.0	5.4	22 x 14	190.5	139.7	3
	85 - 95	25.0	9.0	25.0	5.4	25 x 14	190.5	139.7	3
1065NRTH	64 - 75	20.0	7.5	20.0	4.9	20 x 12	203.2	149.2	3
	75 - 85	22.0	9.0	22.0	5.4	22 x 14	203.2	149.2	3
	85 - 95	25.0	9.0	25.0	5.4	25 x 14	203.2	149.2	3
	95 - 110	28.0	10.0	28.0	6.4	28 x 16	203.2	149.2	3
	110 - 115	32.0	11.0	32.0	3.5	32 x 14	203.2	149.2	3
1085NRTH	100 - 110	28.0	10.0	28.0	6.4	28 x 16	193.7	149.2	3
	110 - 130	32.0	11.0	32.0	7.4	32 x 18	193.7	149.2	3
	130 - 140	36.0	12.0	36.0	3.8	36 x 15	193.7	149.2	3
1075NRT	58 - 65	18.0	7.0	18.0	4.4	18 x 11	210	210	2
	65 - 75	20.0	7.5	20.0	4.9	20 x 12	200	185	2
	75 - 85	22.0	9.0	22.0	5.4	22 x 14	180	160	2
	85 - 95	25.0	9.0	25.0	5.4	25 x 14	150	140	2
	95 - 100	28.0	10.0	28.0	4.9	28 x 14.5	180	140	2
1085NRT	75 - 85	22.0	9.0	22.0	5.4	22 x 14	210	210	2
	85 - 95	25.0	9.0	25.0	5.4	25 x 14	210	210	2
	95 - 110	28.0	10.0	28.0	6.4	28 x 16	180	170	2
	110 - 130	32.0	11.0	32.0	7.4	32 x 18	150	120	2
1095NRT	95 - 110	28.0	10.0	28.0	6.4	28 x 16	265	265	2
	110 - 130	32.0	11.0	32.0	7.4	32 x 18	230	225	2
	130 - 150	36.0	12.0	36.0	7.4	36 x 19	180	160	2
1105NRT	120 - 130	32.0	11.0	32.0	7.4	32 x 18	265	265	2
	130 - 150	36.0	12.0	36.0	8.4	36 x 20	265	265	2
	150 - 170	40.0	13.0	40.0	9.4	40 x 22	220	210	2
	170 - 200	45.0	15.0	45.0	10.4	45 x 25	170	165	2
1115NRT	150 - 170	40.0	13.0	40.0	9.4	40 x 22	290	290	2
	170 - 200	45.0	15.0	45.0	10.4	45 x 25	290	280	2
	200 - 225	50.0	17.0	50.0	11.4	50 x 28	220	220	2
1125NRT	180 - 200	45.0	15.0	45.0	10.4	45 x 25	305	305	2
	200 - 230	50.0	17.0	50.0	11.4	50 x 28	305	305	2
	230 - 240	56.0	20.0	56.0	12.4	56 x 32	280	250	2
1135NRT	210 - 230	50.0	17.0	50.0	11.4	50 x 28	350	350	2
	230 - 260	56.0	20.0	56.0	12.4	56 x 32	350	350	2
	260 - 280	63.0	20.0	63.0	12.4	63 x 32	330	315	2
1145NRT	260	56.0	20.0	56.0	12.4	56 x 32	350	350	2
	260 - 290	63.0	20.0	63.0	12.4	63 x 32	350	350	2
	290 - 300	70.0	22.0	70.0	14.4	70 x 36	350	340	2
1155NRT	290 - 330	70.0	22.0	70.0	14.4	70 x 36	360	360	2
	330 - 350	80.0	25.0	80.0	15.4	80 x 40	360	330	2
1165NRT	320 - 330	70.0	22.0	70.0	14.4	70 x 36	415	395	2
	330 - 380	80.0	25.0	80.0	15.4	80 x 40	415	395	2
	380 - 405	90.0	28.0	90.0	17.4	90 x 45	380	365	2
1175NRT	380 - 440	90.0	28.0	90.0	17.4	90 x 45	430	415	2
	440 - 465	100.0	31.0	100.0	19.5	100 x 50	430	415	2
1185NRT	440 - 500	100.0	31.0	100.0	19.5	100 x 50	450	430	2

① Backstops supplied with E7 bore and D10 keyway assuming m6 shaft diameter and h9 keyway (ISO tolerance specification).

② Number 1 keys are cold drawn 1045 steel. Number 2 keys are heat-treated alloy steel (310 - 350 HB). Number 3 keys are mild steel.

③ Keys are furnished by Rexnord to suit shaft and backstop keyways. Keys are either cold drawn 1045 or heat-treated alloy steel (310 - 350 HB). Only use keys furnished by the Rexnord factory. Shaft keyway depth tolerance of -.000 -.025 mm is recommended.

Engineering Recommendations

Table 2 — Backstop-Shaft Fits — Inch

Nominal Diameter (From-Included)	Nominal Shaft Tolerance	Nominal Bore Diameter Tolerance	Base-Shaft Clearance ^①
1.2500 – 1.5000	+ .0000, – .0005	+ .0005, +.0015	.0005 – .0020
1.5000 – 2.9375	+ .0000, – .0010	+ .0005, +.0015	.0005 – .0025
3.0000 – 7.9375	+ .0000, – .0010	+ .0010, +.0025	.0010 – .0035
8.0000 – 11.9375	+ .0000, – .0010	+ .0015, +.0035	.0015 – .0045
12.0000 – 14.9375	+ .0000, – .0010	+ .0020, +.0045	.0020 – .0055
15.0000 – 20.0000	+ .0000, – .0020	+ .0020, +.0045	.0020 – .0065

③ 125 micro-inch (or finer) shaft finish and clearance fit specified above are recommended.

Table 3 — Metric Bores for Backstops

Nominal Diameter (Over-To) (mm)	Nominal Shaft Tolerance (mm) ^②	Nominal Bore Tolerance (mm) ^③	Bore-Shaft Clearance Min-Max (mm)
30 – 50 k6	.002 / .018	.025 / .050	.007 – .048
50 – 80 m6	.011 / .030	.060 / .090	.030 – .079
80 – 120 m6	.013 / .035	.072 / .107	.037 – .094
120 – 180 m6	.015 / .040	.085 / .125	.045 – .110
180 – 250 m6	.017 / .046	.100 / .146	.054 – .129
250 – 315 m6	.020 / .052	.110 / .162	.058 – .142
315 – 400 m6	.021 / .057	.125 / .182	.068 – .161
400 – 500 m6	.023 / .063	.135 / .198	.072 – .175

② Shaft diameters from 30 – 50 mm are k6 tolerance and shaft diameters over 50 – 500 mm are m6 tolerance.

③ Bore diameters from 30 – 50 mm are F7 tolerance and bore diameters over 50 mm to 500 mm are E7 tolerance.

A 3.2 micro-meter (or finer) shaft finish is recommended. For shaft tolerances other than those listed in the table, consult Factory for bore tolerance (specify your shaft tolerance).

Table 4 — Backstop Reaction Force at Torque Arm Stirrup (Inch & Metric)

Backstop Size	Catalog Torque Rating		N Torque Arm Length (See drawing on next page.)		0.9 X N (rounded)		Torque Arm Reaction Force ^④	
	lb-ft	Nm	in	mm	in	mm	lb	N
1045NRTH-B	2100	2847	7.00	178	6.30	160	6000	26,688
1055NRTH-B	10,000	13,557	36.00	914	32.40	823	5556	24,711
1055NRTH-C	4400	5965	36.00	914	32.40	823	2444	10,873
1065NRTH-B	13,000	17,625	36.00	914	32.40	823	7222	32,124
1065NRTH-C	8400	11,388	36.00	914	32.40	823	4667	20,757
1085NRTH-B	18,000	24,403	51.00	1295	45.90	1166	7059	31,398
1075NRT	10,000	13,600	36.00	914	32.50	825	5550	24,700
1085NRT	16,000	21,700	48.00	1219	43.00	1095	6700	29,800
1095NRT	28,000	38,000	54.00	1372	48.50	1235	10,500	46,700
1105NRT	45,000	61,000	66.00	1676	59.50	1510	13,600	60,500
1115NRT	75,000	102,000	72.00	1829	65.00	1645	20,800	92,550
1125NRT	105,000	142,000	78.00	1981	70.00	1785	27,000	120,100
1135NRT	150,000	203,000	82.00	2083	74.00	1875	36,500	162,400
1145NRT	212,000	287,000	88.00	2235	79.00	2010	48,300	214,850
1155NRT	249,000	338,000	94.00	2386	84.50	2150	53,300	237,100
1165NRT	346,000	469,000	100.00	2540	90.00	2285	69,200	307,850
1175NRT	519,000	704,000	120.00	3048	108.00	2745	86,500	384,850
1185NRT	747,000	1,013,000	120.00	3048	108.00	2745	124,500	553,800

④ Reaction force is based on 0.9 torque arm length and 1.5 catalog rating:

$$\text{Force (lb)} = \frac{1.50 \times \text{Catalog Torque Rating (lb-ft)} \times 12 \text{ (in per ft)}}{0.9 \times N \text{ (in)}}$$

$$\text{Force (N)} = \frac{150 \times \text{Catalog Torque Rating} \times 1000 \text{ (mm per m)}}{0.9 \times N \text{ (mm)}}$$

For reduced length torque arms, substitute actual N dimension in formula.

Table 5 — Key and Keyway Tolerances

Keyway Depth Tolerance = +.010-.010			
Keyway Width Tolerance			
Width		Width Tolerance	
Over	Thru	+	-
0.500	1.000	0.0030	0.0000
1.000	1.500	0.0035	0.0000
1.500	2.000	0.0040	0.0000
2.000	3.000	0.0045	0.0000
3.000	7.450	0.0050	0.0000
4.750	7.000	0.0060	0.0000

All dimensions in inches.

Engineering Recommendations

Backstop Mounting Positions — The supporting shaft must be horizontal within $\pm 5^\circ$ for NRTH and NRT backstops. The backstop torque arm assembly may be rotated to any angular position, but the position must be specified by the purchaser to permit Rexnord to furnish oil lines to suit the mounting for Type NRT.

The symmetrical backstop design permits turning the backstop end for end to provide either direction of shaft rotation. The backstop overrunning (or free rotation) direction is indicated by a rotation arrow on each side of the backstop.

For NRT backstops, the purchaser is responsible for mounting the backstop retaining collar, oil line, oil level sight gauge, and air vent, and for furnishing the oil and the torque arm stirrup per the Rexnord service manual.

Torque Arm Stirrups — Locate torque arm stirrup at $0.9 \times \text{Length (N)}$ as illustrated at right. Design the stirrup to withstand the Torque Arm Reaction Force listed in Table 4. If the stirrup must be located closer, design the stirrup to withstand the force developed by the actual torque applied to the backstop. Use the following formula to determine the force.

$$\text{Actual Reaction} = \frac{\text{Drive Pulley Peak Torque}}{\text{Actual Application Dimension N}}$$

The torque arm must be free to move within the stirrup. Provide clearance on three sides as shown at right. DO NOT restrict torque arm movement by welding or securing to any supporting structure.

Locate the torque arm support surface parallel ($\pm 1/2^\circ$) to the axis of the shaft on which the backstop is mounted.

A boot or hood is recommended for all positions of the torque arm to prevent accumulation of material around the torque arm stirrup. This also provides a guard against a possible pinch point. DO NOT restrict movement of the torque arm.

Grease Purged Seals — It is necessary to add grease to the backstop prior to use (reference manual 568-111 for method and type).

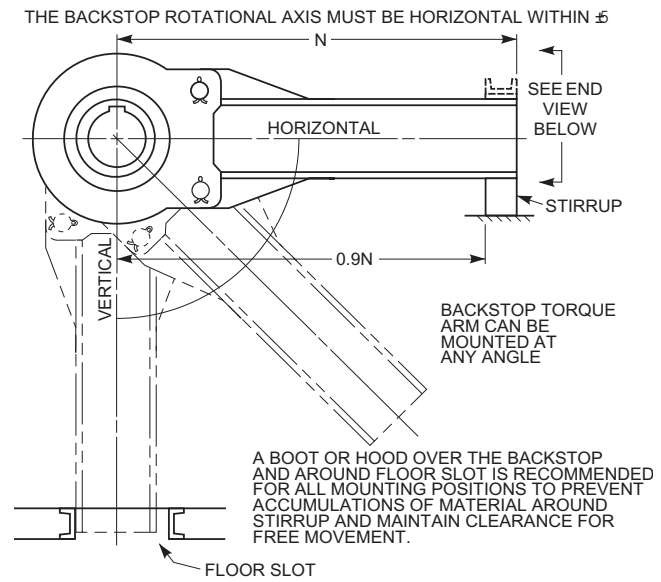

SIDE VIEW

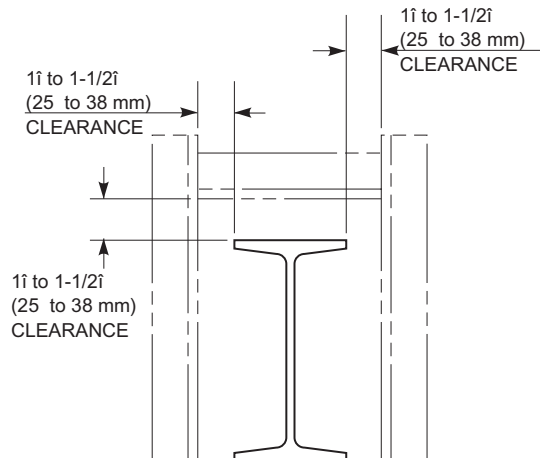

END VIEW

How to Order

The following information, along with selection information from pages 7 thru 10, is required to order a backstop:

- Type of torque used to select (motor, brake, or lift)
- Torque arm mounting position (see pages 7-10)
- Overrunning rotation
- Number of retaining collars

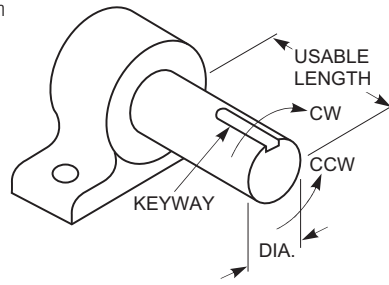

System Characteristics — Supply any information about the system to which the Falk NRT or NRTH backstop is being applied that would affect the selection of the backstop (or holdback); for example, “Are there any torque limiting devices with the motors? Is material feed restricted in any way to prevent overload of the material handling system? Will the system produce overloads that could exceed the motor’s stall torque capacity?”

NRT / NRTH Backstop Order Information Required (or previous Falk M.O. Number)

	Size
	Quantity
	Backstop Rotation (CW or CCW)
	Shaft Diameter and Tolerance (mm or inches)
	Available Shaft Length (mm or inches)
	Kwy ____ x ____ (mm or inches)
	Torque Arm Position in Degrees (See illustrations on pages 7 thru 10)
	If Non-Std Torque Arm, Advise ‘N’ Dim. pages 9 & 10 (inches or mm)
	Power (Indicate kW or Hp, Lift, Demand or Motor)
	RPM of Shaft that Backstop is Mounted Upon
	% Motor Stall Torque or Max. Overload Torque
	% Stall Torque
	Number of Retaining Collars

NOTE: Provide information above, plus a drive layout schematic for multiple pulley applications.

Metric Backstops — supplied with E7 bore and D10 keyway, assuming m6 shaft diameter and h9 keyway (ISO tolerance specification).

Inch Backstops — supplied with H7 bore, assuming h6 shaft (ANSI tolerance specification). Backstop key and keyway tolerance per Table 5 page 17, assuming shaft keyway per ANSI B17.1.

Falk Type NRT & NRTH Backstop Interchangeability Chart (NOTE: All dimensions in imperial units.)

Torque Rating lb-ft	REXNORD/FALK [Ⓢ] NRTH & NRT						ALTRA INDUSTRIAL MOTION [®] (formerly MARLAND [®]) TYPE BC, BC-M, & BC-MA						ALTRA INDUSTRIAL MOTION [®] (formerly FORMSPRAG [®]) TYPE LLH-S & LLH-R					
	Size	Bore Range		Outside Dia	Width w/o Axial Retention	Wt lb	Size	Bore Range		Outside Dia	Width w/o Axial Retention	Wt lb	Size	Bore Range		Outside Dia	Width w/o Axial Retention	Wt lb
		Min	Max					Min	Max					Min	Max			
1,808
2,100	1045NRTHB	1.75	2.50	6.50	4.19	29
2,250
3,000	3MA/2M/200	2.44	2.94	8.2	5.3	100
3,333
4,000	700S	1.88	3.25	7.1	6.4	160	...
4,342
4,400	1055NRTHC	1.75	3.75	9.75	8.02	157
5,000
5,788
6,000	6MA/4M/275	2.94	3.69	9.8	6.3	150
6,500
6,666
6,800	750S	2.25	3.44	8.0	7.4	215	...
7,960
8,400	1065NRTHC	2.50	4.50	10.50	8.52	190
10,000	1055NRTHB 1075NRT	1.75 1.94	3.75 3.94	9.75 11.6	8.02 8.4	157 155
11,500	800S	2.63	4.44	10.0	7.6	325	...
11,577
11,667
12,000	12MA/8M/350	3.94	4.50	11.5	6.5	220
13,000	1065NRTHB	2.50	4.50	10.50	8.64	190
16,000	1085NRT	2.94	5.19	14.1	8.4	270
18,000	1085NRTHB	3.94	5.44	12.00	8.52	260	18MA/12M/425	4.44	5.44	13.5	7.1	330	900S	3.63	5.44	10.0	8.0	570
18,100
19,000
20,833
27,000	27MA/18M/500	5.68	6.50	15.0	8.4	450	1027S	4.94	7.00	15.0	8.2	750
27,083
27,485
28,000	1095NRT	3.44	5.50	15.4	10.6	390
30,000
36,165
45,000	1105NRT	4.94	7.44	19.3	10.6	620	45MA/30M/550	5.94	7.00	17.5	8.8	600	1051S	4.94	7.00	15.0	9.5	800
45,833
63,000	63MA/42M/600	6.94	8.00	19.6	9.3	830	1250R	5.25	8.00	19.6	9.3	830
65,000	1250S	6.75	9.00	20.0	9.8	1,400
65,100
66,667
75,000	1115NRT	5.94	8.44	21.5	11.6	870
90,000	90MA/60M/700	8.00	9.00	23.0	10.5	1,130	1300S/1300R	7.94/5.75	10.0/9.00	21.5/23.0	9.8/10.5	1,700/1,130
90,410
92,500
105,000	1125NRT	7.25	9.00	24.5	12.2	1,130
130,190
135,000	135MA/90M/800	6.75	10.00	25.8	11.8	1,500	1375S/1375R	8.94/6.75	11.0/10.50	24.5/25.7	9.8/11.75	2,200/1,500
145,833
150,000	1135NRT	8.50	10.50	27.0	14.0	1,460
180,000	180MA/120M/900	7.25	11.75	30.3	12.6	2,100	2000R	7.25	11.75	30.3	12.6	2,100
195,290
200,000	2000S	10.94	13.25	30.0	10.4	3,200
208,333
212,000	1145NRT	9.00	12.00	31.0	14.0	1,880
231,460
240,000	240MA/160M/1000	8.25	14.00	34.5	16.0	2,700	2400R	8.75	14.0	34.5	16.0	2,700
249,000	1155NRT	10.50	13.25	35.0	14.3	2,670
250,000
265,000
300,000	300MA	8.25	14.0	34.5	17.0	3,800	2400S	13.00	15.50	36.0	10.6	4,200
316,667
346,000	1165NRT	12.50	15.50	37.2	16.6	3,120
375,000	375MA/250MA/1150	10.25	18.00	41.0	18.7	6,000	3500S/3500R	13.44/10.25	20.0/18.06	38.0/41.0	14.0/18.75	5,050/6,000
376,100
416,667
506,300
519,000	1175NRT	13.50	17.50	43.6	17.4	4,800
540,000	540MA	15.25	21.00	47.0	22.5	9,000	5000R	15.25	21.00	47.0	22.5	9,000
700,000	5000S	13.44	20.00	38.0	14.8	5,930
720,000	720MA	15.25	21.00	47.0	23.5	10,000	5500R	15.25	21.00	47.00	23.5	10,000
747,000	1185NRT	15.50	20.00	50.0	18.0	6,625

Ⓢ All have Nitrile Seals up to 225°.

Falk Type NRT & NRT-H Backstop Interchangeability Chart (NOTE: All dimensions in imperial units.)

Torque Rating lb-ft	EMERSON/MORSE® MG & CB						EMERSON/TSUBAKI BS & BS-HS						STEPHENS ADAMSON® HD					
	Size	Bore Range		Outside Dia	Width w/o Axial Retention	Wt lb	Size	Bore Range		Outside Dia	Width w/o Axial Retention	Wt lb	Size	Bore Range		Outside Dia	Width w/o Axial Retention	Wt lb
		Min	Max					Min	Max					Min	Max			
2100
2250	MG 600	...	2.00	5.4	3.8	19
3000
3333	HD215	1.94	2.94	9.9	8.1	125
4000
4400
5000	MG 700	...	3.25	7.1	5	43
5788	BS-95	2.94	3.74	9.06	4.53	65
6000
6500	CB-7C	2.25	4.00	10.6	5.2	80
6666	MG-750	2.44	3.44	8.75	6.0	84	HD315	2.94	3.94	12.4	8.1	180
7000
7960	BS-110	3.94	4.33	10.63	4.53	75
8400
10,000
11,500
11,577	BS-135	3.54	5.31	12.60	5.31	152
11,667	HD415	3.94	4.94	15.6	8.7	290
12,000	CB-12C	3.25	5.25	12.6	5.7	160
13,000	MG-800	3.00	4.44	10.0	6.0	105
16,000
18,000	MG-900	4.00	5.44	12.0	6.4	158
18,100	BS-160	3.94	6.30	14.17	5.31	192
19,000	CB-19C	3.75	6.25	14.2	5.7	195
20,833
25,000	MG-1000	5.00	6.44	15.0	7.0	253	HD600	4.44	6.00	17.0	11.7	520
27,083
27,485	BS-200	3.94	7.87	16.93	5.91	314
28,913	BS-160-HS	3.94	6.30	14.17	7.08	269
30,000	CB-30C	3.75	7.75	17.0	6.3	330
36,165	BS-220	5.91	8.66	19.69	9.25	590
45,000	CB-45C	5.50	8.50	19.6	9.6	625
45,509	BS-200-HS	3.94	7.87	16.93	8.07	448
45,833
65,000	CB-65C	7.00	9.50	23.8	11.4	1300	HD800	5.94	8.00	23.3	12.5	970
65,100	BS-250	7.09	9.84	23.62	11.61	1280
66,667	HD900	7.00	9.00	27.1	12.5	1,300
75,236	BS-220-HS	5.91	8.66	19.69	12.99	874
90,721	CB-90C	7.87	10.63	25.59	12.6	1610
90,410	BS-270	7.87	10.63	25.59	11.61	1370
92,500
108,425	BS-250-HS	6.89	9.843	23.62	14.57	1702
130,190	BS-300	9.06	11.81	30.71	11.61	1875
135,000
145,833
150,000	CB-150C	8.00	11.50	30.8	11.4	2100	HD1200	9.00	12.00	30.8	16.0	2,450
150,467	BS-270-HS	7.87	10.63	25.59	15.16	1904
195,290	BS-335	9.84	13.19	33.46	12.00	2500
195,456	CB-200C	9.84	13.19	33.47	13.5	3097
208,333
216,850	BS-300-HS	9.06	11.81	30.71	16.73	3136
231,460	BS-350	9.84	13.78	36.61	14.17	3540
240,000
249,000
250,000	CB-250C	9.00	13.50	36.5	13.8	3500
289,133	BS-350-HS	9.84	13.78	36.61	17.32	5152
316,667
346,000
375,000
376,100	CB-375C	12.8	16.73	40.55	19.0	6459	BS-425	12.60	16.73	40.55	17.32	5400
416,667
505,974	CB-500C	13.78	17.72	42.91	19.4	7452
506,300	BS-450	13.78	17.72	42.91	18.90	6218
542,123	BS-425-HS	12.8	16.73	40.55	22.44	7392
700,000
722,832	BS-450-HS	13.78	17.72	42.91	22.44	8233
747,000

Falk Type NRT & NRT H Backstop Interchangeability Chart (Note: All dimensions in imperial units.)

JNG (JingJi) Shanghai JingJi Industry Co., LTD.						
Torque Rating lb-ft	Size	Bore Range		Outside Dia	Width w/o Axial Retention	Wt Lb.
		Min	Max			
6,500
6,666
6,800
7,960
8,400
10,000
11,500
11,577
11,667
12,000
13,000
16,000
18,000
18,100
19,000
20,833
22,127	DSN(NJZ)025	...	6.30	14.17	5.91	...
27,000
27,083
27,485
28,000
29,502	DSN(NJZ)038	...	7.87	16.93	6.30	...
30,000
36,165
44,254	DSN(NJZ)050	...	8.66	19.69	9.45	...
45,000
45,833
63,000
65,000
65,100
66,667
73,756	DSN(NJZ)090	...	9.84	23.62	11.42	...
75,000
90,000
90,410
92,500
105,000
110,634	DSN(NJZ)130	...	10.63	25.59	11.42	...
130,190
135,000
145,833
150,000
162,264	DSN(NJZ)200	...	11.81	30.71	11.42	...
180,000
195,290
200,000
208,333
212,000
221,269	DSN(NJZ)280	...	12.60	33.46	12.60	...
231,460
240,000
249,000
250,000
258,147	DSN(NJZ)330	...	13.78	36.61	14.17	...
265,000
300,000
316,667
331,903	DSN(NJZ)530	...	16.54	40.55	17.72	...
346,000
375,000
376,100
416,667
506,300
519,000
531,045	DSN(NJZ)710	...	17.72	42.91	18.90	...
540,000
700,000
720,000
747,000
774,440	DSN(NJZ)1000	...	20.08	47.24	19.69	...
973,582	DSN(NJZ)1300	...	21.26	51.18	19.69	...
1,290,734	DSN(NJZ)1700	...	24.41	57.09	21.26	...
1,475,124	DSN(NJZ)2000	...	25.59	64.96	25.59	...
1,622,637	DSN(NJZ)2200	...	27.56	70.87	25.59	...

Backstop Selection Procedure Definitions

Application Terms

Brake hp (BHP) Brake kW (BkW)	The calculated load required to operate the equipment. For conveyors, brake hp (kW) is based on the horsepower (kilowatts) required to overcome both friction, and the horsepower (kilowatts) required to lift the load vertically.
Drive Pulley	A pulley mounted on the headshaft which supplies power to move conveyor belt.
Lift hp (LHP) Lift kW (LkW)	Horsepower (kilowatts) required to only lift the load vertically.
Motor hp (MHP) Motor kW (MkW)	Motor nameplate rating.
Motor Starting Torque	Torque that the motor is capable of supplying at zero rpm (rev./min.) for approximately 15 seconds in a design B motor or six seconds in a design C motor to start equipment. Also called locked rotor torque.
Motor Stall Torque	Torque required to stop motor rotor from operating and is generally caused by overload conditions.
Motor Breakdown Torque	Maximum torque the motor produces (at about 75% of speed).
Drive Pulley hp (kW)	Horsepower (kilowatts) supplied to drive pulley.
Single Pulley Drive	One drive pulley provides all power to conveyor.
Tandem Motor Drive	Two motors driving one drive pulley drive.
Tandem Pulley Drive	Two pulleys are used to power conveyor, but are driven by one motor through a dual output drive arrangement. This is not commonly used today.
Dual Pulley Drive	Two pulleys are used to power conveyor and each pulley is driven by a separate motor(s).
Headshaft	Shaft at head or high point of conveyor.
Indexing	Continuous cyclic or periodic applications of the backstop as encountered in the conversion of reciprocating or oscillating motion into intermittent linear motion.
Jogging	Stop/start movement with jerking or jolting motion.

Backstop Terms

Backstop Rating	Catalog torque rating.
Backstop Load	Load applied to the backstop.
Backstop Operation	Engagement of backstop rollers and outer race.
Tandem Backstops	Two backstops on the same drive pulley.
Dual Backstops	Two backstops on the same conveyor, but each on separate drive pulley.



866-REXNORD/866-739-6673 (Within the US)
414-643-2366 (Outside the US)
www.rexnord.com

Why Choose Rexnord?

When it comes to providing highly engineered products that improve productivity and efficiency for industrial applications worldwide, Rexnord is the most reliable in the industry. Commitment to customer satisfaction and superior value extend across every business function.

Delivering Lowest Total Cost of Ownership

The highest quality products are designed to help prevent equipment downtime and increase productivity and dependable operation.

Valuable Expertise

An extensive product offering is accompanied by global sales specialists, customer service and maintenance support teams, available anytime.

Solutions to Enhance Ease of Doing Business

Commitment to operational excellence ensures the right products at the right place at the right time.

REXNORD

Rexnord Company Overview

Rexnord is a growth-oriented, multi-platform industrial company with leading market shares and highly trusted brands that serve a diverse array of global end markets.

Process & Motion Control

The Rexnord Process & Motion Control platform designs, manufactures, markets and services specified, highly engineered mechanical components used within complex systems where our customers' reliability requirements and the cost of failure or downtime are extremely high.

Water Management

The Rexnord Water Management platform designs, procures, manufactures and markets products that provide and enhance water quality, safety, flow control and conservation.